



iJRASET

International Journal For Research in
Applied Science and Engineering Technology



INTERNATIONAL JOURNAL FOR RESEARCH

IN APPLIED SCIENCE & ENGINEERING TECHNOLOGY

Volume: 14 Issue: III Month of publication: March 2026

DOI: <https://doi.org/10.22214/ijraset.2026.78710>

www.ijraset.com

Call:  08813907089

E-mail ID: ijraset@gmail.com

Arduino-Based Automatic Phase Shifter System

Mr. Bhanudas D. Tale¹, Dhanashri M. Pilare², Pushkar S. Karambe³, Vishakha R. Bisane⁴, Anurag A. Patil⁵, Asmita V. Jamne⁶

¹Asso. Prof, Head, ^{2,3,4,5,6} Student, Department of Electrical Engineering, Kavikulguru Institute of Technology and Science Ramtek, Nagpur, Maharashtra, India-441106

Abstract: *The need for better power systems these days comes from how we're relying more on renewable energy in circuits, and that's sort of what pushed this whole project forward. An Arduino-based automatic phase shifter seems like a key way to handle changes in power phases without too much hassle. In this setup, the focus is on designing and building it, then checking how it works in real time. It might not be perfect yet, but the idea is to make power management smoother overall. I think the motivation ties back to making things efficient, especially with all the renewable stuff coming into play more. When we ran the experiments, the results looked good for boosting efficiency and keeping power stable. That stands out as a big plus for industrial uses, where reliability matters a lot. Some parts of the testing felt a bit off at first, but overall, it improved things.*

Keywords: *Automatic Phase Shifter, Arduino Nano, Phase Detection, Relay Control, Power System, Three-Phase System, Power Reliability.*

I. INTRODUCTION

In places where the power grid is not very reliable, like some regions we've read about, three-phase electrical systems often face problems with imbalances or one phase just failing completely. This can cause big disruptions in factories or even at home, and it might damage equipment that needs steady power. For example, if you're using a single-phase load connected to a three-phase source, losing even one phase could make things stop working right away, or at least run poorly. It seems like the demand for constant power is growing a lot these days, both in industrial setups and everyday domestic use. So, to handle this, automatic phase changers are pretty much necessary. They keep the power going by switching the load over to a phase that's still healthy, without any big interruptions. These systems pick up on faults, you know, like when voltage drops too low, or phases don't match up. Then they quickly move things to a working phase, or sometimes even kick in a backup generator. That way, the whole setup gets more tolerant of faults and stays reliable overall.

This paper is about an Arduino-based automatic phase changer that tackles these issues in three-phase systems. It's cost-effective and sensitive enough to monitor things closely. I think it improves on older technologies that just used relays, because the microcontroller here gives better precision in checking phases and responds faster. Some people might say traditional ones are simpler, but this seems more precise, at least from what I understand.

This study seeks to answer: "How can Arduino-based systems be utilised to develop an automatic phase shifter that enhances operational efficiency and stability in power systems?" The significance of this research lies in addressing the challenges posed by fluctuating energy inputs and improving grid reliability.

A. *Objective :*

- To avoid stress and inconvenience in manually changeover of phase.
- To shift automatically load of faulty phase to healthy underloaded phase.

II. LITERATURE REVIEW

Automatic phase changer systems have gained significant importance in ensuring an uninterrupted power supply in three-phase electrical networks. Various studies have focused on improving the reliability, efficiency, and automation of these systems.

The study published in ^[1]IJISETR (2024) presents the design and construction of an automatic phase selector that continuously monitors all three phases and transfers the load to a healthy phase whenever a failure occurs. The system utilizes sensing circuits, relays, and control logic to detect voltage presence and perform fast switching. This approach eliminates the delays and manual effort associated with traditional changeover methods, thereby improving system reliability.

Another study in ^[2]IJLTEMAS (2020) introduces an advanced automatic phase changer with optimal selection. Unlike conventional systems that switch to any available phase, this method selects the most stable phase based on voltage conditions and load requirements.

This ensures reduced voltage fluctuations, better performance of connected equipment, and improved protection for sensitive devices. It also helps in balancing the load across phases, enhancing overall system efficiency.

The review paper published in ^[4]IJERT (2017) provides a detailed analysis of the working principles and circuit design of automatic phase changers. It explains the use of components such as relays, voltage sensors, and control circuits to continuously monitor phase conditions and automatically switch the load during faults. The study also highlights limitations of earlier systems, including a lack of intelligent control, limited load handling capacity, and absence of monitoring features, indicating the need for further improvements.

The study from ^[11]IJPREMS (2023) focuses on the practical implementation of an automatic phase selector using available phase supply. It emphasises the importance of proper component selection and circuit design, including transformers, diodes, voltage sensors, relays, and control units. The system demonstrates reliable and fast switching performance during phase failures and is suitable for domestic, industrial, and commercial applications.

III. SYSTEM ARCHITECTURE

The automatic phase changer system needs three primary components, which consist of voltage sensing equipment and an Arduino Uno microcontroller that decides operations and relay systems that control power distribution from three-phase power sources to single-phase systems. The system enables real-time inspection of all three phases, which allows the microcontroller to detect active phases for continuous power delivery to loads. The voltage sensing module, which detects phase status, uses a step-down transformer and bridge rectifier circuit to transform high AC voltage into a lower DC voltage that the Arduino analog input pins can accept. The rectified voltage enters the Arduino's analog-to-digital converter, which measures voltage levels at different times to use them in future algorithm analysis and phase condition evaluation.

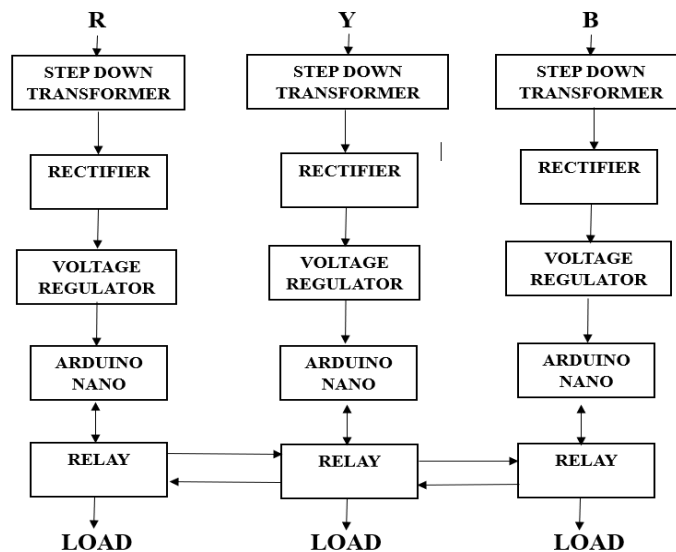

Fig. Block Diagram of Arduino-Based Automatic Phase Shifter

The microcontroller follows its programmed logic to find the safest current phase before it powers the corresponding relay, which links the single-phase load to that specific phase for dependable power delivery. A buffer amplifier that follows the voltage divider circuit will stabilise the microcontroller signal input while reducing noise to maintain accurate voltage measurements that support accurate phase selection. The voltage conditioning process serves as a critical step that enables precise phase evaluation because it determines how well the system will deliver steady power to essential equipment. The filter capacitor, which connects to the rectifier output stage, effectively decreases ripple to improve the quality of the DC signal that reaches the Arduino analog input terminals. The Arduino Uno central processing unit uses voltage measurements to identify phase failures and voltage abnormalities, which trigger the relay module to switch loads onto operational phases. The system continuously observes three input phases while the Arduino runs its programmed algorithm to determine which phase provides a stable voltage for connection.

The block diagram shows an Arduino system that operates an automatic phase changer to maintain continuous power delivery from a three-phase electrical service. The system uses two step-down transformers to reduce high AC line voltage from the R and Y and B phases to safe operating levels for electronic equipment. The system uses a rectifier circuit to convert low AC voltage into a steady DC voltage output. The constant DC voltage is delivered to the Arduino Nano controller after its voltage has been regulated by a voltage regulator. The Arduino Nano serves as the primary control unit for the entire system. The device detects all power phases continuously while it waits to detect which phase of power is operational. The Arduino Nano sends signals to the relays, which function as switches to power the selected phase through the load connection. The system restricts relay operation to one relay at a single time to prevent short circuits from happening between different phases. The system automatically shifts to the next phase when the active phase used for load power fails. All paragraphs must be indented.

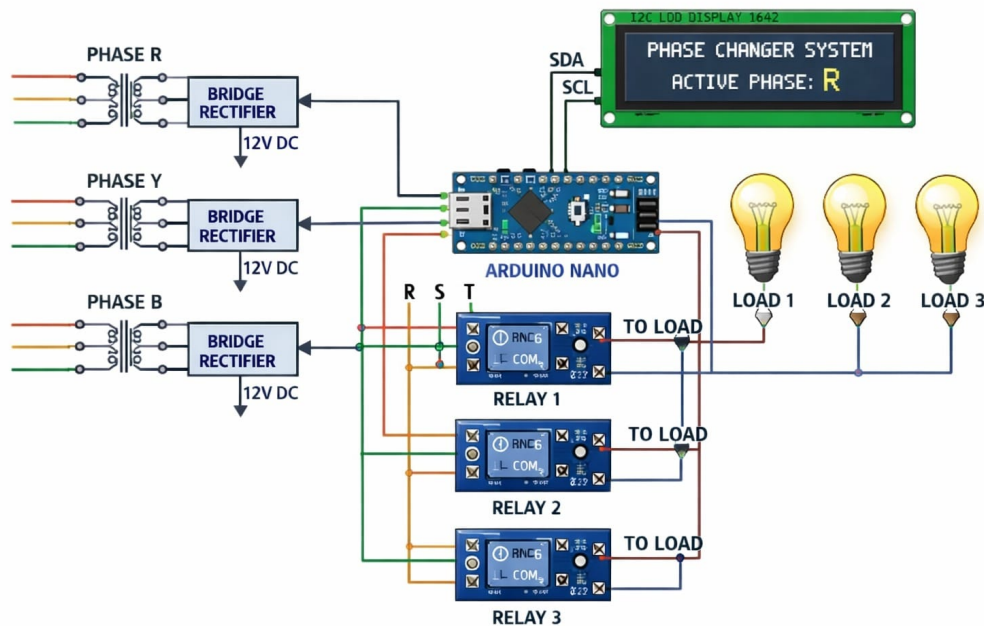

Fig. – Circuit Diagram of Arduino-Base Automatic Phase Shifter

The circuit diagram shows a system which uses Arduino technology to operate an automatic 3-phase power switching mechanism for continuous power delivery through automatic selection of available R, Y, and B phases. The system connects each phase to a step-down transformer which reduces high AC voltage from 230V to a safer output of approximately 12V AC. The system uses a bridge rectifier to transform the low AC voltage into direct current electricity. The Arduino Nano unit receives direct current electricity from all three phases to function as the system's primary control unit.

The Arduino system continuously checks all three phases for voltage presence while identifying the currently active phase. The system uses programmed logic to operate the relay modules because each relay operates a specific phase. The Arduino activates the relay for the available phase which then connects that phase to the load. The design allows only one relay to function at any moment to avoid short circuit occurrences between different phases. The Arduino switches the load to the next available phase immediately after the currently active phase experiences a failure to maintain continuous power delivery. The system status information together with the currently active phase indication appears on the LCD display which connects through I2C using the SDA and SCL lines. The load receives power through the selected phase from the diagrammed bulbs which demonstrate how the system operates through automated processes.

IV. METHODOLOGY

The Arduino-based automatic phase shifter system uses a three-step design process which includes system design and system testing to create a stable power supply system. The system design process starts with key functional blocks which include phase input and voltage sensing and conditioning and control unit and switching mechanism. The system takes three-phase input (R, Y, B) which connects each phase to a step-down transformer that decreases the high voltage to a safer level.

The system first reduces the AC voltage, which then undergoes bridge rectification to produce DC voltage, and through voltage regulation, it delivers a stable voltage for control circuit operation.

The conditioned DC signals from each phase enter the Arduino Nano at the second stage of the process. The Arduino monitors all three phases by tracking their voltage status throughout the entire system. The system uses predefined logic to identify which phase needs to supply power to the load. The system uses a priority sequence that follows $R \rightarrow Y \rightarrow B$ to determine which phase needs selection. The Arduino board transmits control signals to the relay module after making its selection. The relay, which corresponds to the chosen phase, gets triggered to establish a connection between that phase and the load. The other relays maintain their off state at the same time to ensure that only one phase stays active and no short circuit conditions arise.

The system includes an LCD display that shows the currently active phase for system monitoring purposes. The system keeps its operations running in a continuous loop, which checks the current phase status while switching power automatically during phase failures. The system undergoes performance testing through three different testing methods, which include single-phase failure testing, multiple-phase failure testing, and supply restoration testing to evaluate its performance, reliability and response time. The results are analysed to ensure that the system meets the objectives of providing an uninterrupted and safe power supply.

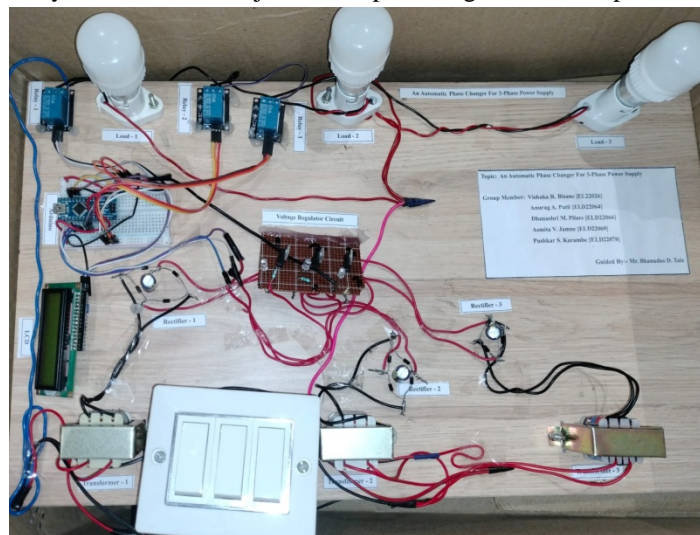

Fig. Hardware Setup of Arduino-Based Automatic Phase Shifter

A. Advantages

The power system operations benefit from the automated phase shifter which uses Arduino technology as its base. The system provides automatic phase switching which removes the manual operation requirement thus decreasing the chances of human mistakes. The system maintains power supply during failures by transferring loads to active phases. The system requires basic components for its implementation because it operates on Arduino and relay technology. The system functions efficiently because it uses reliable design elements that enable fast phase detection and response time. The system increases safety through its switching prevention capabilities while also decreasing the time needed to repair electrical systems.

B. Applications

The system functions as a power solution in environments that need a continuous electricity supply. The system enables residents to run their home appliances continuously without power interruptions. The system keeps industrial machinery operational through its continuous power supply. The system enables businesses to maintain power for their operations across retail spaces, office buildings, and shopping centres. The system provides essential power backup for hospitals and critical infrastructure facilities. The system has applications in both small industrial facilities and automation control systems.

C. Limitations

The system provides several benefits, but it comes with specific restrictions. The system experiences a minor switching delay because of its use of electromagnetic relays.

The system works effectively at low to medium load levels, but high-power applications require system modifications. The system design lacks remote monitoring and control capabilities. The system operation requires accurate voltage detection because sensing circuit errors will stop voltage detection activities.

V. RESULT AND DISCUSSION

The voltage sensing circuit provided was found to be quite reliable in correctly detecting the presence/absence of the respective phase. Moreover the processing of the Arduino and the control system was accurate and without errors. Similarly, if R and Y phase is failed then B phase is ON so softly.

During test results, if all the three phases were detected, then the phase was always prioritized to be the 'R' phase and hence the load will not turn off at all. And even if the phase R fails, Arduino Nano will precisely detect no voltage there and relay of 'Y' phase will be switched on to feed the load. Also, in case the R and Y phase fails then B phase will be turned on so smoothly.

The voltage sensing circuit used proved to be reliable and correctly detects the presence/absence of the respective phase. Also the processing by Arduino and control system was accurate and without error. The switching action of the relay worked perfectly and enabled connection of a single phase to the load.

VI. CONCLUSION

This is a reliable, efficient and inexpensive way to continuously supply the three-phase systems with energy. It does this by continually checking for the presence of all the phases and automatically switching over the loads to the live phase, thereby bypassing the faulty phase. Arduino Nano was selected, as it's easier to integrate and program the accurate decision-making power and swift response. The switching is performed with the help of a relay, which will not produce a spark. The system is designed with a simple structure and low cost, thus suitable for domestic use and small-scale industries. This demonstrates the capability that reliability increases along with security.

VII. FUTURE SCOPE

- 1) A mobile app for real-time updates and alerts could be handy for users to stay on top of things.
- 2) It has the potential to upgrade for bigger industrial gear that pulls a lot of power, maybe handling higher demands without much change.

VIII. ACKNOWLEDGMENT

We would like to express our sincere gratitude to our project guide for their valuable guidance, support, and encouragement throughout the completion of this project. We are also thankful to the faculty members of our department for providing the necessary resources and knowledge. We are grateful to everyone who contributed directly or indirectly to the successful completion of this project.

REFERENCES

- [1] I. Usman, "Design and construction of an automatic phase selector for 3-phase power supply," International Journal of Innovative Scientific & Engineering Technologies Research, vol. 12, no. 3, pp. 64–70, Jul. Sept. 2024.
- [2] S. ABUTU, "Automatic Phase Changer with Optimal Selection," International Journal of Latest Technology in Engineering, Management & Applied Science (IJLTEMAS), vol. IX, Issue V, May 2020.
- [3] R. Patil, P. Rajput, D. Marathe, and Y. Mahajan, "3-Phase Switching System with Relay Mechanism," International Research Journal of Engineering and Technology (IRJET), vol. 11, no. 11, pp. 559–562, Nov. 2024.
- [4] V. Tippa, A. Kedar and K. Nikum, "Automatic phase changer: A review," Int. J. of Engineering Research & Technology (IJERT), ICIATE-2017 Conference Proceedings, vol. 5, no. 1, Special Issue, 2017.
- [5] P. G. Wankhade, M. P. Dongre, A. G. Vigne, S. S. Chaudhari, M. R. Chinche, K. Quazi, and S. Jalit, "Automatic phase selector with regulating power supply," Int. J. of Research and Analytical Reviews (IJRAR), vol. 9, no. 2, pp. 369–372, May 2022.
- [6] C.L. WADHWA - "ELECTRICAL POWER SYSTEMS" (6th edition, New Age International Publishers)
- [7] D. P KOTHARI, I J NAGRATH - "POWER SYSTEM ENGINEERING" (2nd edition), 2007
- [8] GIORGIO RIZZONI - "ELECTRICAL ENGINEERING" (7th edition, McGraw INC.), 2004
- [9] M. A. Mazidi, J. G. Mazidi, and R. D. McKinlay, "The 8051 Microcontroller and Embedded Systems," Pearson Education, 2006.
- [10] Simon Monk, Programming Arduino: Getting Started with Sketches, McGraw-Hill Education, 2016.
- [11] R. Patel and S. Desai, "Automatic Phase Selector Implementation Using Amongst Available Phase Supply," International Journal of Progressive Research in Engineering Management and Science (IJPREMS), vol. III, no. V, pp. XX–XX, May 2023.



10.22214/IJRASET



45.98



IMPACT FACTOR:
7.129



IMPACT FACTOR:
7.429



INTERNATIONAL JOURNAL FOR RESEARCH

IN APPLIED SCIENCE & ENGINEERING TECHNOLOGY

Call : 08813907089  (24*7 Support on Whatsapp)