



# IJRASET

International Journal For Research in  
Applied Science and Engineering Technology



---

# INTERNATIONAL JOURNAL FOR RESEARCH

IN APPLIED SCIENCE & ENGINEERING TECHNOLOGY

---

**Volume:** 2026    **Issue:** Conference    **Month of publication:** May 2026

**DOI:** <https://doi.org/10.22214/ijraset.2026.83179>

[www.ijraset.com](http://www.ijraset.com)

Call:  08813907089

E-mail ID: [ijraset@gmail.com](mailto:ijraset@gmail.com)



# Eco-Efficient Laser Beam Machining Integrating Green Technology with Advanced Manufacturing Systems

Subhadip Ray<sup>1</sup>, Avishek Mandal<sup>2</sup>

<sup>1,2</sup>Department of Mechanical Engineering, Future Institute of Engineering and Management, Sonarpur, 700150, India

**Abstract:** It should be noted that Laser Beam Machining (LBM) has become a revolutionary technology that allows for obtaining high precision, low tool wear and versatility in working with different materials. Against the backdrop of the growing environmental awareness and transition of industry to sustainable manufacturing, LBM attracts considerable interest as one of the most important technologies that can ensure the development of green manufacturing. This review is dedicated to studying the problem of ecoefficient laser beam machining in the framework of advanced manufacturing and green technologies. In particular, the work will describe the fundamentals of LBM as well as analyze some issues related to the interaction between laser beam and material, heat transfer and process parameters. It is necessary to pay special attention to new types of lasers – fiber, ultrafast and diode-pumped solid-state lasers due to their increased energy efficiency, less negative impact and sustainability; the use of LBM in intelligent manufacturing systems, such as digital monitoring, automation, and optimization, is explored as an approach to create sustainable industrial ecosystems. Moreover, the paper deals with the evaluation of the impact of the process on the life cycle, energy consumption, and carbon footprint. New inventions in LBM regarding sustainability, including the use of hybrid machining, adaptive control, and use of renewable energy, are discussed. Future research directions in the field, which would involve efforts to improve process efficiency and minimize environmental impact, are proposed in the concluding section of the paper.

**Keywords:** Laser Beam Machining, Sustainable Manufacturing, Green Technology, Energy Efficiency, Eco-Friendly Processing.

## I. INTRODUCTION

It is notable to mention that Laser Beam Machining (LBM) has proved to be a revolutionary technology in the field of machining processes. Contrary to other manufacturing techniques, LBM involves focusing of a laser beam on a workpiece material surface with the aim of causing melting, burning, or vaporization of material through localized heating process [1-4]. This manufacturing process does not necessarily require any form of mechanical contact and, therefore, it is not associated with excessive material wear like other methods [5-6]. The importance of LBM technology can only be recognized in highly precise and micro-scale manufacturing in different fields including aerospace, biomedical engineering, electronics, and automotive production [7-8].

As much as machining processes are vital in manufacturing, it has been discovered that most traditional technologies are not environmentally friendly because of their adverse effects on the environment [9-11]. The major problem associated with these technologies is the large amounts of material wastages generated, the requirement for cutting fluids, and high energy consumption during production. It becomes quite difficult to ensure that these processes will remain sustainable in the future. However, laser beam machining provides an environmentally sustainable manufacturing technology since it can minimize these challenges [12-13]. Moreover, developments in laser technologies, including the emergence of fiber, ultrafast, and diode-pumped solid-state lasers, have greatly increased the energy efficiency and environmental performance of the LBM technology. Modern devices ensure improved beam quality, minimize thermal effects, and reduce expenses, thus, allowing using the LBM technology for more environmentally friendly purposes [14-17]. In addition, the use of LBM technology in combination with digital manufacturing tools, such as automation, monitoring, and artificial intelligence, will enhance its contribution to creating sustainable industrial ecosystems.

While all those features can be considered among the key benefits of the LBM technology in terms of sustainable manufacturing, there are also several challenges that need to be taken into account [18-20]. They include the significant amount of energy used in the process, high initial expenditures, and inability to apply the technology to some materials. Given all those aspects, conducting a comprehensive review on the subject matter becomes critically important.

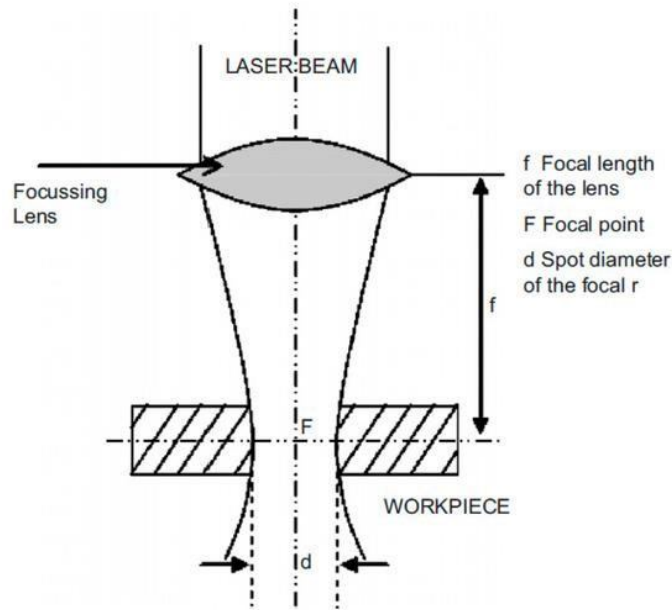

Fig 1. Beam profile schematic for laser beam machining applications. Reproduced with permission from Pramanik et al., *Metals*, 13(9), 1536. (2023). Copyright 2023 Authors, licensed under a Creative Commons Attribution (CC BY) license.

TABLE I  
COMPARISON OF CONVENTIONAL MACHINING AND LASER BEAM MACHINING

Parameter	Conventional Machining	Laser Beam Machining (LBM)
Tool Contact	Direct contact with tool	Non-contact process
Tool Wear	High	Negligible
Material Removal	Mechanical cutting	Thermal (melting/vaporization)
Precision	Moderate	Very high
Material Compatibility	Limited (hard materials difficult)	Wide range (metals, ceramics, polymers)
Use of Cutting Fluids	Required	Minimal or not required
Waste Generation	High	Low
Environmental Impact	Higher	Lower
Energy Efficiency	Moderate	High (with advanced lasers)

## II. OBJECTIVES

One of the main goals of the current paper is going to be assessing the usefulness of LBM in sustainable manufacturing. As industries increasingly pay attention to environment-friendly processes, there is a need for an assessment whether new manufacturing technologies can be classified as sustainable. Thus, this work is aimed at gaining an insight into the potential of LBM technologies from this perspective.

Another important purpose of the paper is to evaluate the principles of LBM technology and their contribution to making ecoefficient machining processes possible. The analysis will be focused on such issues as the nature of laser-material interaction and its effects, thermal properties of processes, and the role played by different process parameters in achieving optimal results in the context of sustainability.



Fig 2. Green technology is integrated with advanced manufacturing systems in eco-efficient laser beam machining.

It is important to mention that the impacts of innovative lasers, such as fiber lasers, ultrashort pulsed lasers, and diode-pumped solid-state lasers (DPSSLs), should also be considered. Innovations have proved to be more effective in terms of energy efficiency, small heat-affected zones, and process stability, which contributes greatly to waste reduction and lowering of the environmental load [21-23]. The review also intends to explore the possibilities of using LBM alongside with intelligent and digital manufacturing systems. Application of automation technologies, monitoring of the processes, and optimization of the procedures will help to improve the process and reduce consumption. Moreover, the environmental effect of LBM should be assessed by carrying out LCA, analyzing energy consumption, and evaluating the carbon footprint of the process [24-26]. In order to understand which factors affect environmental performance of LBM, we need to identify them.

TABLE 2  
TYPES OF LASERS USED IN LBM AND THEIR CHARACTERISTICS

Laser Type	Key Features	Advantages	Limitations
Fiber Laser	Solid-state, optical fiber medium	High efficiency, low maintenance	High initial cost
Ultrafast Laser (Femtosecond)	Extremely short pulse duration	Minimal heat-affected zone, high precision	Expensive, complex system
CO <sub>2</sub> Laser	गैस-based laser	Good for non-metals, high power	Lower efficiency, bulky system
Diode-Pumped Solid-State (DPSS)	Semiconductor-pumped crystal laser	Compact, energy efficient	Limited power compared to fiber
Nd:YAG Laser	Solid-state laser	Suitable for metals, stable output	Moderate efficiency

Finally, it is important to suggest possible future research directions and technological innovations that may further enhance eco-efficiency of LBM.

### III. METHODOLOGY

In this research work, the use of a systematic and comprehensive review technique will be employed in examining the role of Laser Beam Machining (LBM) in sustainable manufacturing and green technology. This technique includes gathering, evaluating, and synthesizing data from various sources such as research studies, review studies, and technical papers regarding LBM techniques and laser machines as well as their performance in terms of sustainability and environment [27-29].

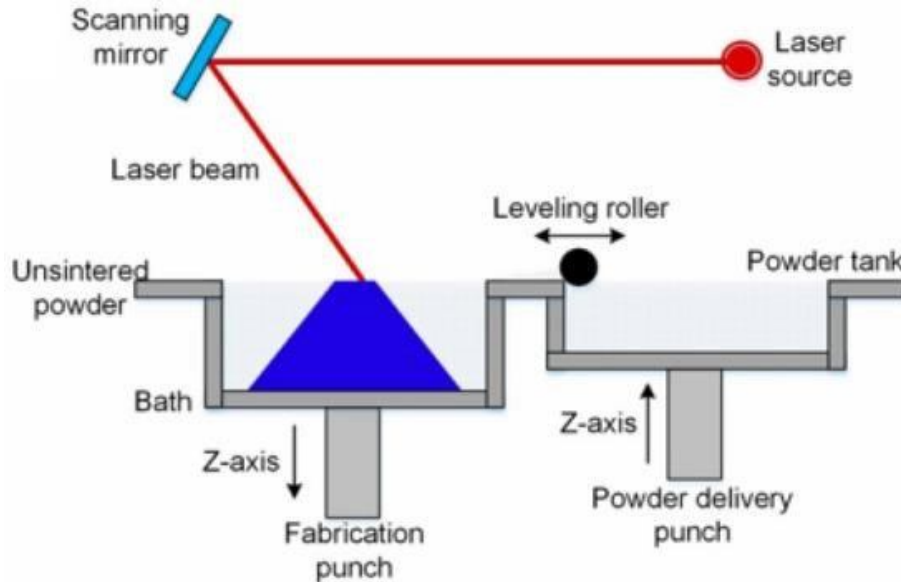

Fig 3. Diagram of SLS from laser sintering to 3D CAD design. Reproduced with permission from Dipta et al., *Journal of Manufacturing and Materials Processing*, 9(8), 269. (2025). Copyright 2025 Authors, licensed under a Creative Commons Attribution (CC BY) license.

The initial stage of this methodology is an examination of basic concepts of LBM techniques. Such concepts include the mechanism of laser-material interaction, the nature of energy absorption and heat transfer during machining operation [30-32]. All these concepts are essential for comprehending the effects of machining variables on machine performance.

TABLE 3  
SUSTAINABILITY ASSESSMENT OF LBM

Sustainability Aspect	LBM Performance	Impact on Environment
Energy Consumption	Moderate to High	Can be reduced with efficient lasers
Material Waste	Very Low	Reduces raw material usage
Emissions	Low	Lower greenhouse gas emissions
Cutting Fluids Usage	Minimal	Reduces chemical pollution
Carbon Footprint	Lower than conventional methods	Supports green manufacturing
Noise Pollution	Low	Safer working environment
Recycling Potential	High (less contamination)	Promotes circular economy

Also, the method comprises an evaluation of new technologies in laser machines like the fiber laser, ultrafast laser, and diode-pumped solid state laser [32-34]. These technologies will be assessed on the basis of their sustainability concerning energy efficiency and accuracy. Comparative assessment will be done to identify whether or not the technology is suitable for sustainable production applications.

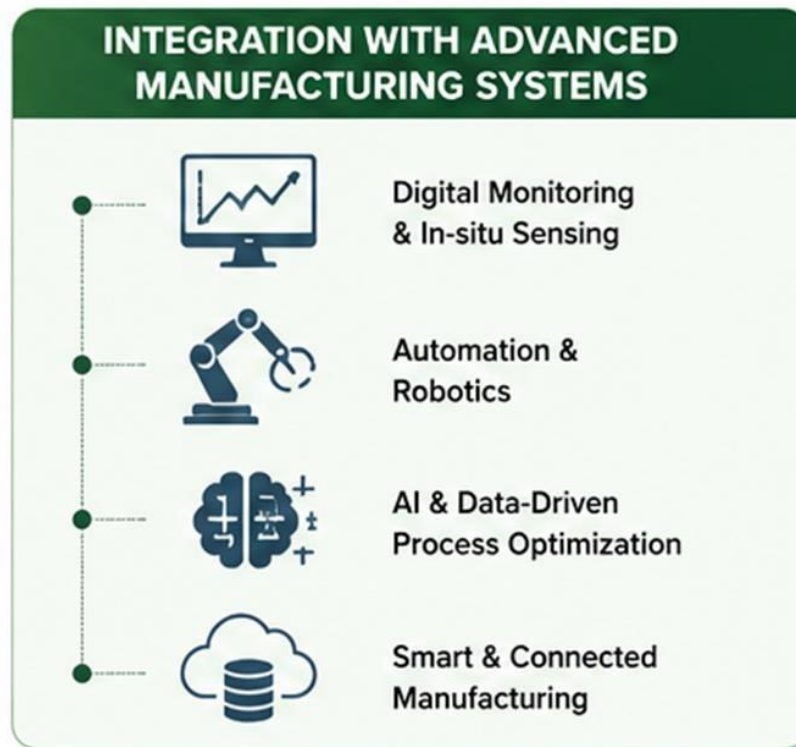

Fig 4. LBM integration with advanced manufacturing systems.

In addition to this, LBM incorporation into intelligent manufacturing systems will also be covered. This includes the evaluation of different approaches and technologies utilized in intelligent manufacturing that include the utilization of feedback mechanisms in digital operations, process automation, and artificial intelligence. All these technologies enable real-time control of the process, greater accuracy, and reduced energy wastage, and therefore, enhance sustainability [35-37].

Another key step of the methodology is that of environmental evaluation. Life cycle assessment technologies are used to evaluate the impact of LBM operations on the environment due to energy usage, emissions, and waste production. Other methods that could be used in environmental assessment include carbon footprint assessment and energy consumption modelling [38-39]. Such approaches will be evaluated to establish the extent of their role in enhancing the sustainability of LBM.

TABLE 4  
KEY CHALLENGES AND FUTURE DIRECTIONS IN LBM.

Category	Current Challenges	Future Directions
Economic	High initial investment	Cost reduction through mass adoption
Technical	Difficulty with reflective materials	Advanced beam control and coatings
Energy	High operational energy demand	Integration with renewable energy sources
Process Control	Sensitivity to parameter variation	AI-based adaptive control systems
Skill Requirement	Need for skilled operators	Automation and user-friendly interfaces
Sustainability	Limited LCA data availability	Comprehensive environmental modeling
Innovation	Limited hybrid integration	Development of hybrid and multi-process systems



#### IV. CONCLUSIONS

The use of Laser Beam Machining (LBM) in Sustainable Manufacturing highlights the vast capabilities of LBM as an ecoefficient process. The first factor associated with LBM is its ability to considerably minimize wastage. It is because LBM is known for its accuracy and precision in material removal. Thus, unlike in conventional machining techniques, where a significant amount of material is wasted during production, LBM makes it possible to effectively conserve materials by minimizing waste. Another significant feature about LBM is that it is a non-contact method, hence eliminating tool wear and tear. An important thing to be noted from the analysis of the reviewed article is the limited use of cutting fluid in LBM. Cutting fluid has long been used in conventional machining as coolant but poses serious environmental risks, mainly pollution. However, LBM requires minimal use of cutting fluid. In addition, with recent advancements in laser technology, including the application of fiber and ultrafast lasers, energy efficiency has been greatly enhanced through reduced thermal damage.

Incorporation of LBM into the modern concept of smart manufacturing systems provides further possibilities of LBM sustainability. In particular, technologies, including real-time monitoring and artificial intelligence, provide precise control of process parameters, minimizing waste of energy and optimizing productivity. Optimization methods based on big data analysis help improve machining processes continuously to achieve effective resource utilization. On the other hand, there are several drawbacks related to laser beam machining discussed in the research. One of the problems with laser machining is the relatively high price and high-energy consumption required by the technology. Besides, not all materials can be machined by lasers efficiently, specifically reflecting and heat-sensitive ones. Nevertheless, these disadvantages are constantly being improved by researchers. New approaches, including hybrid machining systems, adaptive controls, and utilization of sustainable energy sources, can potentially increase LBM efficiency and expand material capabilities of the technology. This indicates that LBM will continue being one of the central technologies for green manufacturing in the future. The following directions should be addressed to improve LBM in the future.

#### V. ACKNOWLEDGMENT

The data that support the findings of this study are available from the corresponding author upon reasonable request. The authors have no conflicts to disclose.

#### REFERENCES

- [1] Zhong, Z. W. (2021). Processes for environmentally friendly and/or cost-effective manufacturing. *Materials and manufacturing processes*, 36(9), 9871009.
- [2] Okonkwo, P. A., & Udeh, G. C. (2025). The role of precision mechanics and digital fabrication in sustainable and green manufacturing practices. *Precis. Mech. Digit. Fabr.*, 2(4), 249-276.
- [3] Lanzilotti, C. O., Pinto, L. F. R., Facchini, F., & Digiesi, S. (2022). Embedding product-service system of cutting tools into the machining process: an eco-efficiency approach toward sustainable development. *Sustainability*, 14(3), 1100.
- [4] Dipta, S. D., Rahman, M. M., Ansari, M. J., & Uddin, M. N. (2025). A Comprehensive Review of Sustainable and Green Additive Manufacturing: Technologies, Practices, and Future Directions. *Journal of Manufacturing and Materials Processing*, 9(8), 269.
- [5] Slamani, M., Louhichi, B., Amroune, S., & Jawaid, M. (2026). Next-Generation Composite Materials and Manufacturing: A Review of Smart, Sustainable, and Digital Advancements. *Advanced Materials Technologies*, e01409.
- [6] Ahmadi, M., Rahmatabadi, D., Karimi, A., Koohpayeh, M. H. A., & Hashemi, R. (2023). The role of additive manufacturing in the age of sustainable manufacturing 4.0. In *Sustainable manufacturing in industry 4.0: Pathways and practices* (pp. 57-78). Singapore: springer nature Singapore.
- [7] Pramanik, A., & Basak, A. K. (2023). Laser Beam Machining of Titanium Alloy—A Review. *Metals*, 13(9), 1536. <https://doi.org/10.3390/met13091536>
- [8] Dipta, S. D., Rahman, M. M., Ansari, M. J., & Uddin, M. N. (2025). A Comprehensive Review of Sustainable and Green Additive Manufacturing: Technologies, Practices, and Future Directions. *Journal of Manufacturing and Materials Processing*, 9(8), 269. <https://doi.org/10.3390/jmmp9080269>
- [9] Barua, R., Datta, S., Datta, P., & Roychowdhury, A. (2022). Study and application of machine learning methods in modern additive manufacturing processes. In *Applications of Artificial Intelligence in Additive Manufacturing* (pp. 75-95). IGI Global Scientific Publishing.
- [10] Dubey, A. K., & Yadava, V. (2008). Laser beam machining—A review. *International Journal of Machine Tools and Manufacture*, 48(6), 609-628.
- [11] Akinlabi, E. T., Agarana, M. C., & Akinlabi, S. A. (2021). Advances in manufacturing, laser additive techniques: case study. *Modeling and Optimization in Manufacturing: Toward Greener Production by Integrating Computer Simulation*, 253-302.
- [12] Datta, S., Barua, R., & Prasad, A. (2023). Additive manufacturing for the development of artificial organs. *Advanced materials and manufacturing techniques for biomedical applications*, 411-427.
- [13] Waidi, Y. O., Jain, N., Chowdhury, S., Barua, R., Das, S., Prasad, A., & Datta, S. (2024). Challenges and perspective of manufacturing techniques in biomedical applications. In *Applications of Biotribology in Biomedical Systems* (pp. 433-445). Cham: Springer Nature Switzerland.
- [14] Datta, S., Waidi, Y. O., & Barua, R. (2025). 3D Printing of Bioabsorbable Polymeric Composites in Biomedical Applications. In *Bioabsorbable Polymers for Drug Carriers and Fixation Devices* (pp. 243-266). Apple Academic Press.
- [15] Barua, R., Das, S., Roy Chowdhury, A., & Datta, P. (2023). Experimental and simulation investigation of surgical needle insertion into soft tissue mimic biomaterial for minimally invasive surgery (MIS). *Proceedings of the Institution of Mechanical Engineers, Part H: Journal of Engineering in Medicine*, 237(2), 254-264.



- [16] Chowdhury, S., Jain, N., Waidi, Y. O., Barua, R., Das, S., Prasad, A., & Datta, S. (2024). Biological smart biomaterials: materials for biomedical applications. In *Applications of Biotribology in Biomedical Systems* (pp. 313-325). Cham: Springer Nature Switzerland.
- [17] Rusho, M. A., & Yishak, S. (2025). Bridging Plant Biotechnology and Additive Manufacturing: A Multicriteria Decision Approach for Biopolymer Development. *Advances in Polymer Technology*, 2025.
- [18] Canciglieri Jr, O., Sant'Anna, Á. M. O., & Machado, L. C. (2015). Multi-attribute method for prioritization of sustainable prototyping technologies. *Clean Technologies and Environmental Policy*, 17(5), 1355-1363.
- [19] Rejeski, D., Zhao, F., & Huang, Y. (2018). Research needs and recommendations on environmental implications of additive manufacturing. *Additive Manufacturing*, 19, 21-28.
- [20] Okonkwo, P. A., & Udeh, G. C. (2025). The role of precision mechanics and digital fabrication in sustainable and green manufacturing practices. *Precis. Mech. Digit. Fabr.*, 2(4), 249-276.
- [21] Khan, M. A., Ahmad, R., Jaffery, S. H. I., Butt, S. I., Khan, M. S., & Zahid, D. (2025). Sustainability analysis of tool wear, energy efficiency, surface quality, and energy during dry, MQL, and wet turning of Inconel 718. *International Journal of Sustainable Energy*, 44(1), 2515447.
- [22] Moawad, E. (2019). A Stochastic Eco-Efficiency Approach to Support the Eco-Design of Additive Manufactured Components in the Aircraft Industry. *Ecole Polytechnique, Montreal (Canada)*.
- [23] Díaz Lantada, A., de Blas Romero, A., Sánchez Isasi, Á., & Garrido Bellido, D. (2017). Design and performance assessment of innovative ecoefficient support structures for additive manufacturing by photopolymerization. *Journal of Industrial Ecology*, 21(S1), S179-S190.
- [24] Cendrero, A. M., Fortunato, G. M., Munoz-Guijosa, J. M., De Maria, C., & Díaz Lantada, A. (2021). Benefits of non-planar printing strategies towards eco-efficient 3d printing. *Sustainability*, 13(4), 1599.
- [25] Sun, S., & Brandt, M. (2013). Laser beam machining. In *Nontraditional Machining Processes: Research Advances* (pp. 35-96). London: Springer London.
- [26] Parandoush, P., & Hossain, A. (2014). A review of modeling and simulation of laser beam machining. *International journal of machine tools and manufacture*, 85, 135-145.
- [27] Meijer, J. (2004). Laser beam machining (LBM), state of the art and new opportunities. *Journal of materials processing technology*, 149(1-3), 2-17.
- [28] El-Hofy, M. H., & El-Hofy, H. (2019). Laser beam machining of carbon fiber reinforced composites: a review. *The International Journal of Advanced Manufacturing Technology*, 101(9), 2965-2975.
- [29] Pramanik, A., & Basak, A. K. (2023). Laser beam machining of titanium alloy—A review. *Metals*, 13(9), 1536.
- [30] Kharache, P. P., & Patil, V. H. (2024). Systematic review of optimization techniques for laser beam machining. *Engineering Research Express*, 6(2), 022507.
- [31] Behera, R. R., & Sankar, M. R. (2015). State of the art on under liquid laser beam machining. *Materials today: proceedings*, 2(4-5), 1731-1740.
- [32] Rao, K. V., Raju, L. S., Suresh, G., Ranganayakulu, J., & Krishna, J. (2024). Modelling of kerf width and surface roughness using vibration signals in laser beam machining of stainless steel using design of experiments. *Optics & Laser Technology*, 169, 110146.
- [33] Lee, S. W., Shin, H. S., & Chu, C. N. (2013). Fabrication of micro-pin array with high aspect ratio on stainless steel using nanosecond laser beam machining. *Applied Surface Science*, 264, 653-663.
- [34] Chun, D. M., Davaasuren, G., Ngo, C. V., Kim, C. S., Lee, G. Y., & Ahn, S. H. (2014). Fabrication of transparent superhydrophobic surface on thermoplastic polymer using laser beam machining and compression molding for mass production. *CIRP Annals*, 63(1), 525-528.
- [35] Muthuramalingam, T., Akash, R., Krishnan, S., Phan, N. H., Pi, V. N., & Elsheikh, A. H. (2021). Surface quality measures analysis and optimization on machining titanium alloy using CO2 based laser beam drilling process. *Journal of Manufacturing Processes*, 62, 1-6.
- [36] Jagadeesha, T., & Kunar, S. (2025). Laser Beam Machining. *Advanced Machining and Micromachining Processes*, 77-91.
- [37] Ji, M., Thangaraj, M., Devaraj, S., Machnik, R., Karkalos, N. E., & Karmiris-Obratański, P. (2024). Prediction and optimization kerf width in laser beam machining of titanium alloy using genetic algorithm tuned adaptive neuro-fuzzy inference system. *The International Journal of Advanced Manufacturing Technology*, 132(11), 5873-5893.
- [38] Eaysin, A., Kabir, S., Gunister, E., Jahan, N., Hamza, A., Zinnah, M. A., & Rashid, A. B. (2025). Process parameter optimization of laser beam machining for AISI-P20 mold steel using ANFIS method. *Results in Surfaces and Interfaces*, 18, 100357.
- [39] Zhou, Y., Huang, Z., Chen, Y., Dong, X., Fan, F., Chen, L., & Feng, B. (2025). Laser Beam Machining of Janus Porous Electrodes for Long-term Electrophysiological Sensing. *Advanced Materials Technologies*, 10(13), 2401812.



10.22214/IJRASET



45.98



IMPACT FACTOR:  
7.129



IMPACT FACTOR:  
7.429



# INTERNATIONAL JOURNAL FOR RESEARCH

IN APPLIED SCIENCE & ENGINEERING TECHNOLOGY

Call : 08813907089  (24\*7 Support on Whatsapp)