



IJRASET

International Journal For Research in
Applied Science and Engineering Technology



INTERNATIONAL JOURNAL FOR RESEARCH

IN APPLIED SCIENCE & ENGINEERING TECHNOLOGY

Volume: 13 **Issue:** IV **Month of publication:** April 2025

DOI: <https://doi.org/10.22214/ijraset.2025.68582>

www.ijraset.com

Call:  08813907089

E-mail ID: ijraset@gmail.com

IOT based Solar Powered Seed Sowing Machine and Spray System

Prof. Pankaj Pandey¹, Md Hasnain², Jaish Anzar³, Mohommad Arshad⁴, Dhiraj Kumar⁵, Gautam Kumar Shah⁶, Satendra Kumar Kushwaha⁷, Avinash Kumar⁸

¹Professor, ^{2,3,4,5,6,7,8}Students, Department of Mechanical Engineering, Oriental Institute Of Science and Technology, Bhopal, Madhya Pradesh, India

Abstract: *The seed sowing machine is the main equipment of the agriculture field. It is used for seed sowing and plantation. Population increasing rapidly day by day, therefore, it is necessary to meet the food demands hence it has to be developed seed sowing machine. Traditional method consumes more power as well as time with less efficiency. Labor availability becomes a major problem for farmers. This machine requires less man power as well as overall cost. So it is important to develop more efficient methods. Application of non-conventional energy is the only another option to fulfill demands. In this paper, the development of solar-powered seed sowing machine is mentioned.*

Keywords: *Solar, Seed sowing machine, Spray pump*

I. INTRODUCTION

Seed sowing machine is a technology which provides the direction for sowing seeds in the required position. Therefore overall time, as well as money, can be saved. The target of this operation is to put seeds in rows at a specific depth and to maintain space between two corresponding seeds. This paper provides totally different aspects of seed sowing machine which can be useful for agriculture demands. The agricultural industry provides 50% of employment of the total population. The population increases continuously, the demand also increases respectively. Hence, there is a lot of demand for multiple cropping in an exceedingly same farm and this requires more efficiency and capacity. Mechanization of the Agricultural industry in India is still in traditional due to the lack of knowledge of updated inventions. In ancient ways, seed sowing is finished by broadcasting manually, gap furrows by a plough and dropping seeds by hand. This can be replaced by using automated techniques.

II. LITERATURE SURVEY

Ayesha Akhtar and et al., studied the information about different types of innovations done in seed sowing machine. This machine is the main equipment of the agriculture field. The aim of sowing technique is to put the seeds in rows at specific depth and space between seeds.

R. Joshua V. Vasu and P. Vincent are discussed the “Energy-demand” is the major problem for India. Finding solutions, to meet these demands is a difficult challenge for Social Scientist and Engineers. This paper deals how a ‘Power’ which is already in uses and works with fossil fuel can be converted into a solar operated machine.

Ibukun B. Ikechukwu et al., focused on the planning and fabrication of an operated by hand single row maize planter capable of delivering seeds exactly in an exceedingly line with uniform depth within the fur row and with uniform spacing between the seeds.

Roshan V. Marode et al., in the traditional method, the rate of seed sowing is more but the total operating time is more and the labour cost is much more. Today’s aim is to go towards the rising of all sectors as well as the agricultural sector. New techniques have to be implemented to achieve future demands by the farmers, which will not affect the soil but crop production will be increased.

III. COMPONENTS

- 1) Chassis
- 2) Battery
- 3) Solar panel
- 4) DC motor
- 5) Centrifugal pump

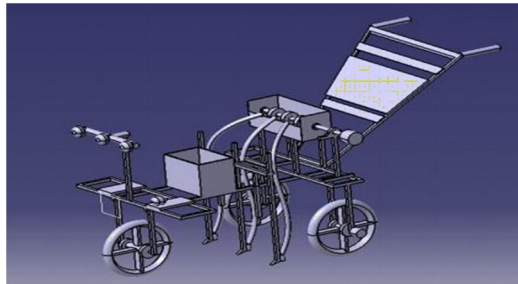

Fig.1: Catia Model

A. Chassis

This consists of an internal framework that supports a complete body. An example of a chassis is the under part of a motor vehicle, consisting of the frame. If running wheels are included then the assembly is described as a rolling chassis. The material used in chassis – cast Iron, Size of chassis – 22 x 8 x 36 inches.

B. Centrifugal Pump

Centrifugal pump is a device which moves the fluid by means of rotational energy. In this project submerged type centrifugal pump is used for spraying the fertilizer.

- Liquid Discharge $Q=0.4$ to 1 lit/min.
- Speed: 3600 rpm.
- Power $P:3.5$ W
- Voltage $V:12$ V
- Current $I:0.5$ to 1.5 A
- Fluid pressure: 1.6 kgf/cm²

C. Battery

A battery is a component consisting of chemical science that converts chemical energy into electrical. Each cell contains a positive terminal (cathode) and a negative terminal (anode). Electrolyte enables ions to move in-between the electrodes and terminals, which permits current to flow out of the battery to perform work. According to the pump operating power, the battery is selected.

Type: Lead acid battery.

Voltage $V=12$ V Current $I=2.4$ A

Power $P=$ Voltage x Current $=12 \times 2.4=28.8$ W

D. Solar Panel

Solar cell provided in the panel is used to collect solar energy. These cells convert solar energy into electrical, based on the principle of photovoltaic effect. This electricity so obtained can directly be used to charge the batteries. A Solar panel consists of a number of solar modules, which are connected in series and parallel configuration to provide specific voltage and current to charge a battery. According to battery output power, the solar panel is selected.

$P=20$ W

Dimension $=520$ mm \times 20 mm \times 340 mm $W = 2.0$ kg

$V=21.7$ V

$I=1.176$ A

E. DC motor

Conversion of electrical energy into mechanical is done by an electric motor. The principle of the motor is stated by Fleming's Left-Hand Rule when a current carrying conductor is placed in a magnetic field, it experiences a force.

Torque = 5 N-m Speed = 30 rpm Power $=2\pi NT/60$

$= (2 \times 3.14 \times 30 \times 5) / 60$

$P=15.7$ watt.

IV. WORKING PRINCIPLE

A. Seed Sowing

When the equipment is pushed forward by rotating DC motors provided at the rear shaft of wheel begin to rotate and rotation is then transferred to the rear wheel. Seed mechanism will rotate by rotating motor provided at the shaft; circular seed feeder which is mounted on the shaft will also be rotated by rotating the shaft. It will lift the seed from seed box and throwing into the pipe then it will go under soil through the pipe.

B. Spray Pump

The working of the system is as follows: the sprayer motor is turned ON and OFF using the push button. Energy conversion unit provides energy to the sprayer. Submerged type pump is placed in a fertilizer tank which sprays fertilizer in the required amount by using a suitable nozzle.

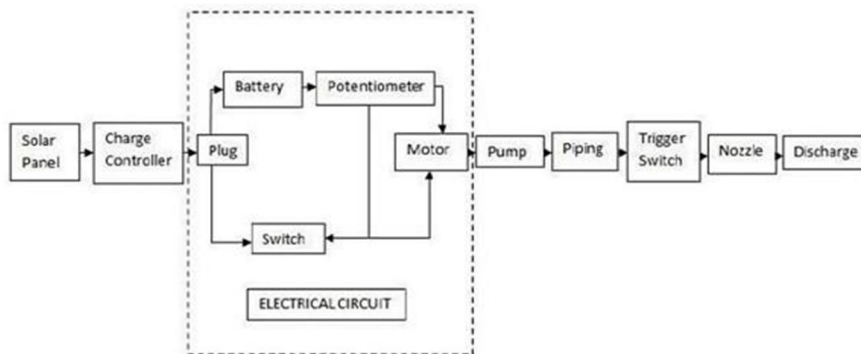

Fig.2: Block diagram of the spraying system

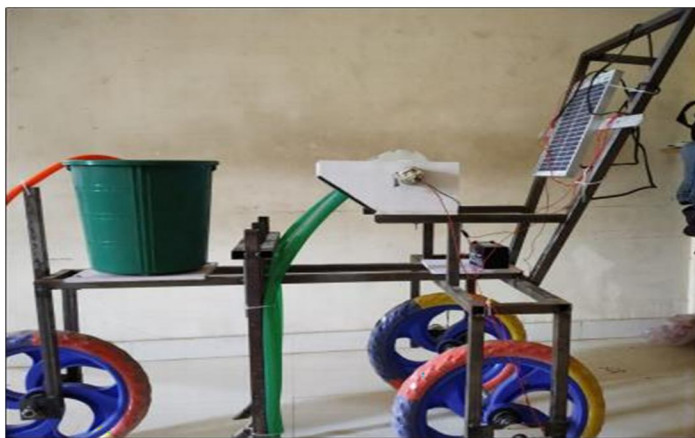

Fig.3: Actual model

V. ADVANTAGES

- 1) No conventional grid electricity required
- 2) Long operating life
- 3) Highly reliable and durable
- 4) Easy to operate and maintain
- 5) Eco-friendly
- 6) The space between the two seeds is maintained properly.
- 7) Required depth can be maintained.
- 8) One or more seeds can be sown by a single machine.
- 9) Mixed cropping can be done.
- 10) Overall Cost of seed sowing machine is reduced by using this technique.

VI. APPLICATIONS

A. Industrial Purpose

- It can be used in industry for light duty material handling.
- It can be used for spraying paint.

B. Agricultural purpose

- It is used for spraying chemicals on the plant.
- It is used for seed sowing.
- It can be used for watering the gardens & plants.

C. Domestic purpose

- Used for water lifting.
- Used for washing cars and other equipment.

VII. CONCLUSION

This Project is with success applied for seed sowing and spraying use. Performance of the parts can be increase once it operates on a less uneven surface and potency is inflated once the height of the crops is the same and distance between pair of crops is minimum. Innovative Seed sowing instrument has additional necessities in agriculture. By using this innovative seed sowing machine, the time needed and labor price can be reduced. It is much beneficial for little scale farmers. After comparing the various methods of seed sowing and drawbacks of the traditional methods, it is concluded that this solar powered seed sowing machine can:

- Maintain space between rows and controls the rate of sowing.
- Control the depth of seed and losses of seeds can be reduced.
- Operate various operations simultaneously.
- Saves the requirement of labour hence labour cost, time and the overall energy consumption are reduced.

REFERENCES

- [1] Mahesh. R. Pundkar and A. K. Mahalle, "A Seed-Sowing Machine: A Review" International Journal of Engineering and Social Science, Volume3, Issue3, Pp-68-74
- [2] Laukik P. Raut, Smit B. Jaiswal and Nitin Y. Mohite, "Design, development and fabrication of agricultural pesticides with weeder", International Journal of Applied Research and Studies, 2013, Volume2, Issue11, Pp-1-8
- [3] D. Ramesh and H. P. Girish Kumar, "Agriculture Seed Sowing Equipments: A Review", International Journal of Science, Engineering and Technology Research, 2014, Volume3, Issue7, Pp-1987-1992
- [4] Pranil V. Sawalakhe, Amit Wandhare, Ashish Sontakke, Bhushan Patil, Rakesh Bawanwade and Saurabh Kurjekar, "Solar Powered Seed Sowing Machine", Global Journal of Advanced Research, Vol-2, Issue-4, Pp-712-717
- [5] Ibukun B. Ikechukwu, AgidiGbabo and Ikechukwu C. Ugwuoke, "Design and Fabrication of a Single Row Maize Planter for Garden Use", Journal of Advancement in Engineering and technology, 2014 Volume 1, Issue 2, Pp 1-7
- [6] Roshan V Marode, Gajanan P Tayade and Swapnil K. Agrawal, "Design and Implementation of Multi-Seed Sowing Machine", Int. J. Mech. Eng. & Rob. Res. 2013, Vol.2, No.4, Pp-422-429
- [7] Ayesha Akhtar, Ankit Munshi and Mohammad Fuzail Qaiser, "Automatic Seed Planter Punching Type", International Journal of Emerging Technology & Research, 2014, Volume1, Issue3, Pp-71-75
- [8] Mohd Taufik Ahmad, "Development of an automated mechanical intra-row weeder for vegetable crops".



10.22214/IJRASET



45.98



IMPACT FACTOR:
7.129



IMPACT FACTOR:
7.429



INTERNATIONAL JOURNAL FOR RESEARCH

IN APPLIED SCIENCE & ENGINEERING TECHNOLOGY

Call : 08813907089  (24*7 Support on Whatsapp)