



# IJRASET

International Journal For Research in  
Applied Science and Engineering Technology



# INTERNATIONAL JOURNAL FOR RESEARCH

IN APPLIED SCIENCE & ENGINEERING TECHNOLOGY

**Volume:** 14    **Issue:** IV    **Month of publication:** April 2026

**DOI:** <https://doi.org/10.22214/ijraset.2026.80003>

[www.ijraset.com](http://www.ijraset.com)

Call:  08813907089

E-mail ID: [ijraset@gmail.com](mailto:ijraset@gmail.com)

# LPG Gas Accident Prevention with GSM Alert

Ritik Titirmare<sup>1</sup>, Gaurav Harinkhede<sup>2</sup>, Gatha Bhandirge<sup>3</sup>, Gauri Duragkar<sup>4</sup>, Dr. Awani S. Khobragade<sup>5</sup>

<sup>1, 2, 3, 4</sup>Student, <sup>5</sup>Professor, Department of Electronics and Telecommunication Engineering Priyadarshini College of Engineering, Nagpur, India

**Abstract:** This research focuses on the analysis and development of an LPG gas accident prevention system using GSM alert technology. The primary objective of the study is to enhance safety measures by detecting gas leakage and immediately notifying users through a GSM-based communication system. The system is designed using gas sensors that continuously monitor LPG levels in the environment. Upon detection of leakage beyond a predefined threshold, the system triggers an alert mechanism, including an alarm and an automated message sent to the user's mobile device. The methodology involves sensor integration, microcontroller-based processing, and GSM module communication for real-time alerts. The results demonstrate that the system effectively detects gas leaks with high accuracy and provides timely notifications, thereby reducing the risk of accidents such as fire outbreaks or explosions. The study concludes that the proposed system is reliable, cost-effective, and suitable for domestic as well as industrial applications, contributing significantly to improved safety and accident prevention.

**Keywords:** Analysis, LPG Detection, GSM Alert, Gas Leakage, Safety System, Accident Prevention.

## I. INTRODUCTION

The increasing use of Liquefied Petroleum Gas (LPG) in domestic and industrial applications has significantly improved convenience and efficiency in daily life. However, LPG is highly flammable, and leakage can lead to severe accidents such as fire outbreaks and explosions, posing serious risks to human life and property. Therefore, ensuring safety in LPG usage has become a critical area of concern.

In recent years, advancements in technology have enabled the development of various gas leakage detection and prevention systems. Researchers have explored the use of sensors, microcontrollers, and wireless communication technologies to design effective safety mechanisms. Among these, GSM-based alert systems have gained popularity due to their ability to provide real-time notifications to users, even from remote locations. These systems integrate gas sensors to detect leakage and immediately send alerts via mobile networks, enhancing response time and reducing potential hazards.

The present study focuses on LPG gas accident prevention using a GSM alert system. It aims to design a reliable and cost-effective solution that can detect gas leakage and promptly notify users, thereby minimizing the chances of accidents. This research contributes to improving safety standards and highlights the importance of adopting smart technologies in everyday applications.

## II. LITERATURE REVIEW

Liquefied Petroleum Gas (LPG) leakage has been identified as a major safety concern in both domestic and industrial environments. Several researchers have proposed different systems to detect gas leakage and prevent accidents using sensor-based and communication technologies. A study by researchers in 2021 introduced a microcontroller-based LPG gas leakage detection system integrated with GSM technology. The system used gas sensors to detect leakage and send SMS alerts to users, significantly improving response time and reducing accident risks. Similarly, IoT-based approaches have been widely explored, where LPG leakage detection systems combine sensors with internet connectivity and GSM modules to provide real-time monitoring and alert mechanisms. Recent advancements in 2023 focused on integrating automatic response systems along with detection. For instance, systems were developed that not only detect leakage but also activate exhaust fans and alarms while sending GSM alerts to users. These systems improve safety by taking immediate preventive actions after detection.

In 2024, further improvements were proposed through automatic gas leakage detection and cut-off systems. These systems include features such as automatic gas valve shut-off and power disconnection to minimize the

## III. PROJECT OBJECTIVES

The main objective of this project is to design and develop an LPG gas accident prevention system using GSM alert technology to enhance safety in domestic and industrial environments. The system aims to continuously monitor the presence of LPG gas leakage using a gas sensor and provide immediate warning signals when leakage is detected.

The specific objectives of the project are as follows:

- 1) To detect LPG gas leakage using a sensitive gas sensor (such as MQ series).
- 2) To process sensor data using a microcontroller for real-time monitoring.
- 3) To generate an instant local alert using a buzzer or alarm system.
- 4) To send an automatic SMS alert to the user through a GSM module during gas leakage.
- 5) To reduce the risk of fire accidents and explosions by ensuring early detection and notification.
- 6) To develop a low-cost, reliable, and efficient safety system suitable for home and industrial applications.

#### IV. RESEARCH METHODOLOGY

The research methodology for the LPG gas accident prevention system using GSM alert focuses on the systematic design, implementation, and testing of a real-time gas leakage detection and alert system. The study integrates hardware and software components to achieve reliable monitoring and immediate notification in case of LPG leakage.

The methodology begins with the selection of an appropriate gas sensor (such as MQ-6) capable of detecting LPG concentration in the surrounding environment. The sensor continuously monitors air quality and sends analog signals based on gas concentration levels. These signals are processed by a microcontroller, which acts as the central control unit of the system.

A threshold value is programmed into the microcontroller. When the gas concentration exceeds this limit, the system activates an alert mechanism. This includes a buzzer for local warning and a GSM module for remote notification. The GSM module sends an SMS alert to a predefined mobile number, ensuring that the user is informed immediately even when away from the location.

The system is tested under different simulated leakage conditions to evaluate its response time, accuracy, and reliability. Performance analysis is carried out by varying gas concentration levels and observing system behavior.

The final stage involves evaluating the system’s effectiveness in real-world conditions. The results confirm that the proposed system provides fast response, accurate detection, and reliable communication, making it suitable for domestic and industrial safety applications.

#### V. BLOCK DIAGRAM

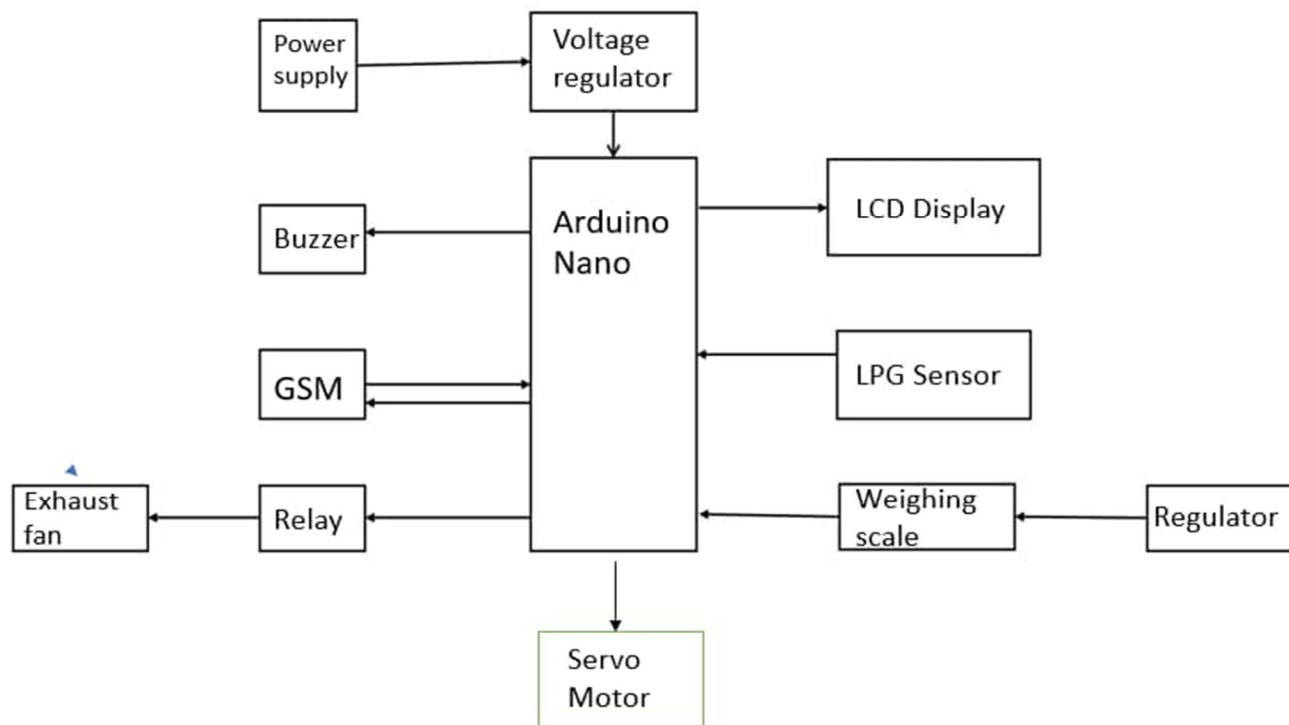

## VI. RESULTS

### A. Insights

- 1) Early detection significantly reduces the risk of fire and explosion accidents.
- 2) GSM alerts improve safety by informing users even when they are away.
- 3) Faster response time increases the effectiveness of emergency prevention.
- 4) Integration of sensor and microcontroller ensures accurate monitoring.
- 5) The system is low-cost and suitable for household and industrial use.
- 6) Future improvements can include IoT-based monitoring and automatic gas shut-off systems.

### B. Applicability

- 1) Suitable for domestic kitchens to detect LPG gas leakage early.
- 2) Can be used in hotels, restaurants, and food industries for safety monitoring.
- 3) Applicable in industrial plants where LPG or other combustible gases are used.
- 4) Useful in laboratories to ensure safe handling of gas cylinders.
- 5) Can be implemented in hostels, apartments, and commercial buildings for fire prevention.
- 6) Helps emergency response by sending instant GSM alerts to users.
- 7) Can be integrated into smart home systems for automated safety control.
- 8) Reduces risk of accidents by providing real-time gas leakage monitoring.
- 9) Can be upgraded for IoT-based remote monitoring and automation in future systems.

## VII. CONCLUSION

The LPG gas accident prevention system using GSM alert was successfully designed and implemented to enhance safety in domestic and industrial environments. The system effectively detects LPG gas leakage using a gas sensor and provides immediate alerts through both a buzzer and GSM-based SMS notification.

The results show that the system responds quickly and accurately when gas concentration exceeds the safety threshold. This early warning mechanism helps in preventing fire accidents and explosions by ensuring timely action from users.

The proposed system is cost-effective, reliable, and easy to implement, making it suitable for widespread use in homes, restaurants, and industries. It improves safety by combining real-time monitoring with remote communication technology.

In conclusion, the system significantly reduces the risk associated with LPG leakage and provides an efficient solution for accident prevention. Future enhancements such as IoT integration, automatic gas shut-off valves, and mobile applications can further improve its performance and reliability.

## REFERENCES

- [1] L. R. Chaudhari et al., "Microcontroller Based Gas Leakage Detection and Accident Prevention System with GSM," International Journal of Engineering Research & Technology (IJERT), 2021.
- [2] Pushpendra Kumar Pateriya et al., "IoT-based LPG Gas Leakage Detection and Prevention System," International Conference on Innovative Computing & Communication (ICICC), 2021.
- [3] Yekini Nureni et al., "Gas Leakage Detector and Monitoring System," International Journal of Engineering and Manufacturing, vol. 12, no. 4, 2022.
- [4] M. Mustofa and A. Fadlil, "Design of IoT-Based LPG Gas Leak Detection System," Buletin Ilmiah Sarjana Teknik Elektro, 2023.
- [5] Bhagyashree Dharaskar et al., "LPG Gas Leakage Detection and Alert System," International Journal for Research in Applied Science & Engineering Technology (IJRASET), 2023.
- [6] Anjali T. Pawar et al., "GSM Based LPG Gas Leakage Detection & Alert," Journal of Artificial Intelligence, Machine Learning and Neural Network, 2023.
- [7] Elsevier, "LPG Gas Leakage Detection System using IoT," Materials Today: Proceedings, 2023.



10.22214/IJRASET



45.98



IMPACT FACTOR:  
7.129



IMPACT FACTOR:  
7.429



# INTERNATIONAL JOURNAL FOR RESEARCH

IN APPLIED SCIENCE & ENGINEERING TECHNOLOGY

Call : 08813907089  (24\*7 Support on Whatsapp)