



IJRASET

International Journal For Research in
Applied Science and Engineering Technology



INTERNATIONAL JOURNAL FOR RESEARCH

IN APPLIED SCIENCE & ENGINEERING TECHNOLOGY

Volume: 14 **Issue:** VI **Month of publication:** June 2026

DOI:

www.ijraset.com

Call:  08813907089

E-mail ID: ijraset@gmail.com

Smart Navigation Voice Controlled Vehicle

Dr B. Ramakrishna¹, Dr. D. Kameswara Rao², Dr. K. Sudhakar Reddy³, M Tharun⁴

^{1,2}Assistant Professor, ³Professor, ⁴UG Student, Dept. of Mechanical Engineering, Mahatma Gandhi Institute of Technology, Hyderabad, Telangana, India

Abstract: A Voice-Controlled vehicle with Object recognition project integrates technologies like speech recognition and computer vision to create an intelligent vehicle that can be controlled through voice commands and can also identify objects in its environment. In defence applications, this system aims to enhance surveillance, reconnaissance, and situational awareness, reduce human risk in hazardous zones, and provide efficient, real-time decision-making support through automated detection and interaction with potential threats. Our project approach will be by means of implementing an Arduino microcontroller into the vehicle chassis and programming it such that the DC motors should be controlled by voice commands and integrating an ultrasonic sensor and a camera with the vehicle to detect objects. The result will be an autonomous vehicle that can be controlled by voice commands and provide the pictures of the detected objects on the connected Android device.

Keywords: Voice-controlled vehicle, object recognition, Programming, voice commands, Arduino microcontroller, ultrasonic sensor, camera, surveillance, reconnaissance, autonomous vehicle.

I. INTRODUCTION

The rapid advancement of technology has revolutionized modern transportation, paving the way for intelligent and user-friendly systems that enhance both functionality and user interaction. One such innovative leap is the integration of voice-controlled smart navigation into vehicles, which aims to significantly improve safety, convenience, and the overall driving experience. This project, titled "Smart Navigation Voice-Controlled Vehicle," is centered around the design and implementation of a prototype vehicle that can receive, interpret, and execute voice commands to navigate and perform essential driving functions.

With the evolution of embedded systems, artificial intelligence (AI), and the Internet of Things (IoT), the development of intelligent vehicles has become a significant area of research and innovation. Automation and smart control in vehicles are increasingly being explored for safety, accessibility, and operational efficiency in both civilian and defence sectors. Voice-controlled systems have emerged as a promising interface due to their intuitive and hands-free nature, which enables seamless interaction between humans and machines.

II. METHODOLOGY

The methodology encompasses the design, development, and testing of a prototype vehicle. The hardware assembly involves the physical integration of an Arduino Uno microcontroller, an Elec house Voice Recognition V3 module, an L298N motor driver, HC-SR04 ultrasonic sensors, and an ESP32-CAM module. The components are mounted on a rigid chassis and powered by a rechargeable 12V battery pack.

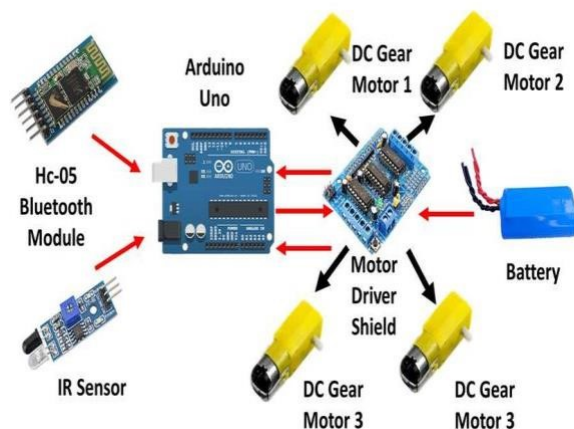

Figure No 1: Hardware Assembly

The circuit wiring ensures seamless communication between modules. The HC-05 Bluetooth module facilitates wireless communication between a mobile device and the vehicle. The motor driver interfaces between the microcontroller and the DC motors, enabling direction and speed control. The ultrasonic sensor detects nearby obstacles for collision avoidance by measuring distance and altering the path via conditional logic.

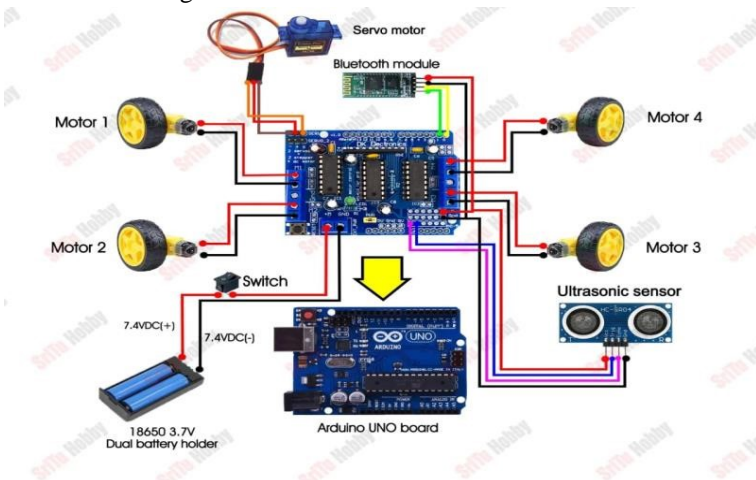

Figure No 2: Circuit Diagram

Table 1. Test Cases

Test Description	Input	Expected Output
Voice command recognition	Forward	Vehicle moves forward
Obstacle avoidance at 15 cm	Obstacle in path	Vehicle stops
Turn left on a command	Left	Vehicle turns left
Stop command response	Stop	All motion halts

III. RESULTS AND DISCUSSION

Testing was conducted in an indoor laboratory environment to validate the functional and non-functional requirements of the system. The vehicle demonstrated high accuracy and reliability in recognizing and executing voice commands in a controlled setting. Obstacle avoidance worked effectively, with a near-instant stop when an object was detected within a 15 cm threshold.

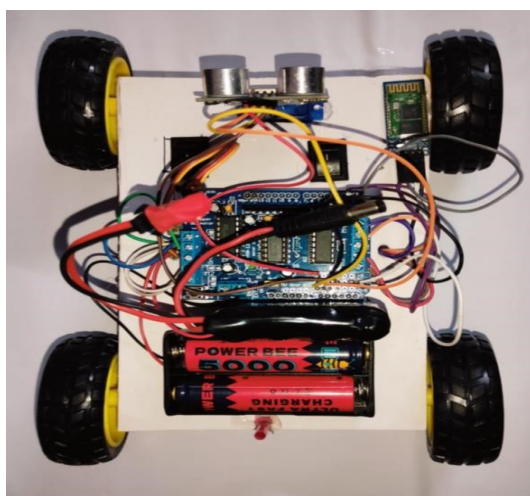

FIGURE 3. Top View of Prototype
Figure No 3: Assembly of voice-controlled vehicle

Table 2. Performance Metrics

Metric	Measured value	Ideal/Threshold
Command Recognition Accuracy	95%	$\geq 90\%$
Obstacle Detection Accuracy	98%	$\geq 95\%$
Bluetooth Range	9.5 Metres	≥ 10 meters
Response Time	~200 ms	≤ 300 ms
Battery Life	~90 Minutes	≥ 60 minutes

Commands issued in rapid succession were handled efficiently without crashes. The system successfully filtered out vague or unsupported commands, indicating a robust command parser. While minor delays were noted near the maximum Bluetooth range, the overall system responsiveness remained well within the acceptable limits.

IV. CONCLUSION

The Smart Navigation Voice-Controlled Vehicle project successfully designed and developed a mobile robotic system controlled via voice commands with intelligent obstacle avoidance capabilities. The system integrates voice recognition through a smartphone, Bluetooth communication for wireless control, and an Arduino-based microcontroller. The project involved hardware assembly, circuit design, software development, and real-time testing. Testing confirmed the accuracy, responsiveness, and reliability of the vehicle under normal conditions, demonstrating its potential applications in assistive technology, education, and service robotics.

REFERENCES

- [1] P. Sharma and V. Singh, "Voice controlled robot using Android application," International Journal of Engineering Research & Technology (IJERT), vol. 7, no. 3, pp. 245-248, Mar. 2018.
- [2] V. A. Bhosale and R. Thakur, "Obstacle avoiding robot using ultrasonic sensor," International Research Journal of Engineering and Technology (IRJET), vol. 4, no. 6, pp. 1230-1234, Jun. 2017.
- [3] S. Monk, Programming Arduino: Getting Started with Sketches, 2nd ed. New York, NY, USA: McGraw-Hill Education, 2016.
- [4] R. Buyya and A. V. Dastjerdi, Internet of Things: Principles and Paradigms. Cambridge, MA, USA: Elsevier, 2016.
- [5] M. A. Ali, M. A. H. Khan, and M. R. Islam, "Smart voice-controlled wheel chair using Arduino," in Proc. International Conference on Electrical, Computer and Communication Engineering (ECCE), Cox's Bazar, Bangladesh, 2017, pp. 1-4.
- [6] K. Kannan and S. Thilagavathi, "Android based voice controlled robot," International Journal of Advanced Research in Electrical, Electronics and Instrumentation Engineering, vol. 3, no. 2, pp. 7192-7197, Feb. 2014.
- [7] A. A. Kumar and S. M. Girirajkumar, "Smart autonomous robotic vehicle with ultrasonic obstacle avoidance system," in Proc. IEEE International Conference on Intelligent Techniques in Control, Optimization and Signal Processing (INCOS), Srivilliputtur, India, 2019, pp. 1-5.
- [8] J. Borenstein and Y. Koren, "The vector field histogram-fast obstacle avoidance for mobile robots," IEEE Transactions on Robotics and Automation, vol. 7, no. 3, pp. 278-288, Jun. 1991.
- [9] S. R. V. K. Raju, P. S. S. N. V. K. V. Prasad, and B. V. R. Reddy, "Development of Bluetooth based voice controlled robot using Arduino," International Journal of Recent Technology and Engineering (IJRTE), vol. 8, no. 2, pp. 3125-3129, Jul. 2019.
- [10] S. S. Kulkarni and A. B. Deshmukh, "Voice operated intelligent wheel chair based on embedded system," in Proc. International Conference on Pervasive Computing (ICPC), Pune, India, 2015, pp. 1-4.



10.22214/IJRASET



45.98



IMPACT FACTOR:
7.129



IMPACT FACTOR:
7.429



INTERNATIONAL JOURNAL FOR RESEARCH

IN APPLIED SCIENCE & ENGINEERING TECHNOLOGY

Call : 08813907089  (24*7 Support on Whatsapp)