



IJRASET

International Journal For Research in
Applied Science and Engineering Technology



INTERNATIONAL JOURNAL FOR RESEARCH

IN APPLIED SCIENCE & ENGINEERING TECHNOLOGY

Volume: 14 **Issue:** IV **Month of publication:** April 2026

DOI: <https://doi.org/10.22214/ijraset.2026.79626>

www.ijraset.com

Call:  08813907089

E-mail ID: ijraset@gmail.com

Solar Pizeo Hybrid Charging System

Arman Mulani¹, Mithesh Dhumal², Aditya Dalvi³, Tejas Bhosale⁴, Siddhesh Desai⁵

Department of Electrical Engineering Vivekanand Education Society's Polytechnic

Abstract: *The efficient utilization and management of renewable energy sources have become increasingly important in modern electrical systems. This paper presents a hybrid energy management system that integrates solar and piezoelectric energy sources using an ESP32-based control architecture. The proposed system enables controlled switching between multiple operating modes using relay-based logic, ensuring optimal energy flow and utilization. Solar energy is used for charging a battery, while piezoelectric energy is stored in a capacitor. The system allows manual mode selection through a Bluetooth-enabled graphical user interface (GUI), ensuring flexibility in operation. Voltage sensing mechanisms are incorporated to monitor battery status and energy source utilization in real-time. The system also displays data on an I2C LCD for local monitoring. This approach enhances energy efficiency, provides real-time control, and ensures safe operation of hybrid renewable systems. Although the system requires careful design and integration, it offers a scalable and cost-effective solution for energy management applications.*

Index Terms: *ESP32, Solar Energy, Piezoelectric System, Relay Control, Hybrid Energy, Bluetooth GUI.*

I. INTRODUCTION

With the growing demand for sustainable energy solutions, hybrid energy systems combining multiple renewable sources have gained significant attention. Solar energy is widely used due to its reliability and availability, while piezoelectric energy offers an innovative method to harvest mechanical vibrations and convert them into electrical energy.

However, managing multiple energy sources efficiently requires proper control and switching mechanisms. Conventional systems lack flexibility in controlling energy flow and often do not provide real-time monitoring or user interaction.

This project introduces an ESP32-based hybrid energy management system that integrates solar and piezoelectric energy sources. The system uses relay-based switching to operate in four distinct modes, allowing selective charging and discharging of energy storage elements such as batteries and capacitors. A Bluetooth-enabled GUI allows the user to manually select modes, while voltage sensors provide real-time monitoring of battery status. The system also displays operational data on an LCD, enhancing usability and monitoring capabilities. This solution improves control, efficiency, and adaptability in hybrid renewable energy systems.

II. LITERATURE SURVEY

Recent research has focused on hybrid renewable energy systems and smart monitoring technologies to improve efficiency, reliability, and energy utilization. With the increasing demand for sustainable power solutions, combining multiple energy sources and integrating intelligent control systems has become a key area of development.

Malek et al., "Design and Implementation of Sustainable Solar Energy Harvesting System" [1]: This study highlights the design of solar energy systems integrated with real-time monitoring and battery storage. It emphasizes the importance of efficient energy conversion, proper charge regulation, and continuous performance monitoring to ensure system reliability. The work also demonstrates how sensor-based monitoring improves system efficiency and reduces energy losses.

Jettanasen et al., "Development of Piezoelectric Energy System" [2]: This research focuses on the conversion of mechanical vibrations into electrical energy using piezoelectric materials. It explains the working principles of piezoelectric transducers and their application in harvesting low-level energy from environmental sources such as pressure and motion. The study provides insights into improving output efficiency and practical implementation of piezo-based systems.

Juanda et al., "Micropower Design of Energy Harvesting using Piezoelectric Array" [3]: This work concentrates on enhancing energy generation by using multiple piezoelectric sensors arranged in arrays. It discusses the importance of circuit design, including rectifiers and storage elements like capacitors, to maximize energy extraction. The study shows how combining multiple sensors increases output power and improves system performance.

"IoT-Enabled Piezoelectric Energy Harvesting System" [4]: This study integrates piezoelectric energy harvesting with IoT-based monitoring systems. It demonstrates how real-time data collection, wireless communication, and remote monitoring can improve system control and usability.

The use of microcontrollers and communication modules enables efficient tracking of energy generation and system status.

“Piezo and Solar Based Power Generation and Smart Grid System using ESP32” [5]: This research presents a hybrid system that combines solar and piezoelectric energy sources using an ESP32 microcontroller. It utilizes relay-based switching and control mechanisms to manage energy flow between sources and loads. The study highlights the advantages of integrating multiple renewable sources with intelligent control for improved energy utilization.

These studies collectively demonstrate the importance of combining renewable energy sources, efficient energy storage techniques, and smart control systems. They form the foundation for the proposed system, which integrates solar and piezoelectric energy with ESP32-based control, relay switching, and real-time monitoring to achieve an efficient and flexible hybrid energy management solution.

III. SYSTEM OVERVIEW

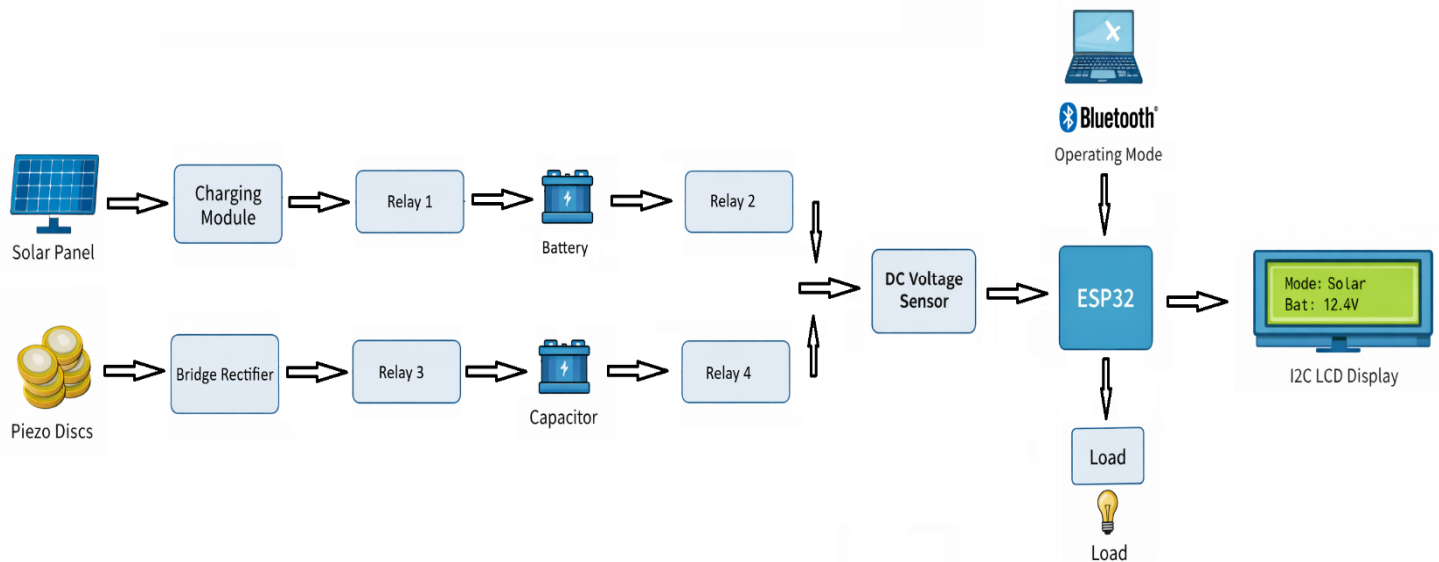

Fig.1.BLOCKDIAGRAM

The proposed system integrates multiple renewable energy sources, intelligent control logic, and user interaction modules to ensure efficient energy generation, storage, and utilization. The system is designed to operate in a controlled manner using relay-based switching, allowing selective connection between energy sources, storage elements, and load. The ESP32 microcontroller acts as the core unit, coordinating all operations, monitoring system parameters, and enabling communication with external interfaces. This architecture ensures flexibility, safety, and real-time control in hybrid energy management.

1) ESP32 Microcontroller:

The ESP32 serves as the central processing and control unit of the system. It is responsible for managing relay switching based on user-selected modes, acquiring data from the voltage sensor, and processing this data for monitoring purposes. The ESP32 also enables wireless communication through built-in Bluetooth, allowing interaction with a PC-based GUI. Its fast processing capability and multiple GPIO pins make it suitable for handling simultaneous tasks such as control, sensing, and communication.

2) Solar Panel and Charging Module:

The solar panel converts sunlight into electrical energy in the form of DC voltage. However, the output of the solar panel may vary depending on environmental conditions such as sunlight intensity. Therefore, a charging module is used to regulate and stabilize the voltage before supplying it to the battery. This module ensures safe charging by preventing overcharging, overcurrent, and voltage fluctuations, thereby increasing battery life and system reliability.

3) Piezoelectric Discs with Bridge Rectifier:

Piezoelectric discs generate electrical energy when mechanical stress or vibrations are applied. The output from these discs is typically in the form of alternating current (AC), which is not suitable for direct storage.

Hence, a bridge rectifier is used to convert this AC output into direct current (DC). The rectified output is then stored in a capacitor, which acts as a temporary energy storage element. This setup allows the system to utilize otherwise wasted mechanical energy.

4) Relays (4 Units):

Four relays are used to control the flow of energy within the system. Each relay is responsible for activating a specific mode of operation. The relays act as electrically controlled switches that isolate or connect different parts of the circuit. The four modes are:

- Solar to Battery: Enables charging of the battery using solar energy.
- Battery to Load: Supplies stored battery energy to the load.
- Piezo to Capacitor: Stores energy generated from piezo discs into the capacitor.
- Capacitor to Load: Supplies stored energy from the capacitor to the load.

Only one relay is activated at a time to prevent overlapping connections and ensure safe operation.

5) Battery and Capacitor:

The battery is used as the primary energy storage device for solar energy due to its higher storage capacity and ability to supply power over longer durations. The capacitor, on the other hand, is used for storing piezoelectric energy, which is typically low in magnitude and intermittent in nature. The combination of battery and capacitor allows efficient utilization of both steady and fluctuating energy sources.

6) DC Voltage Sensor:

A DC voltage sensor is used to continuously monitor the battery voltage. It provides real-time feedback to the ESP32, which helps in assessing the battery condition and system performance. The sensor operates using a voltage divider principle, allowing higher voltages to be safely measured by the microcontroller's ADC pins.

7) I2C LCD Display (16x2):

The LCD display provides a local interface for monitoring system status. It displays important parameters such as the active mode, battery voltage, and energy source in use. The use of I2C communication reduces wiring complexity and allows efficient data transfer between the ESP32 and the display.

8) Bluetooth GUI:

A PC-based graphical user interface (GUI) is used to control the system wirelessly via Bluetooth. The user can select any of the four operating modes using buttons in the GUI. Commands are transmitted to the ESP32, which then activates the corresponding relay. The GUI also receives real-time data such as battery voltage and system status, providing a user-friendly monitoring and control platform.

IV. METHODOLOGY

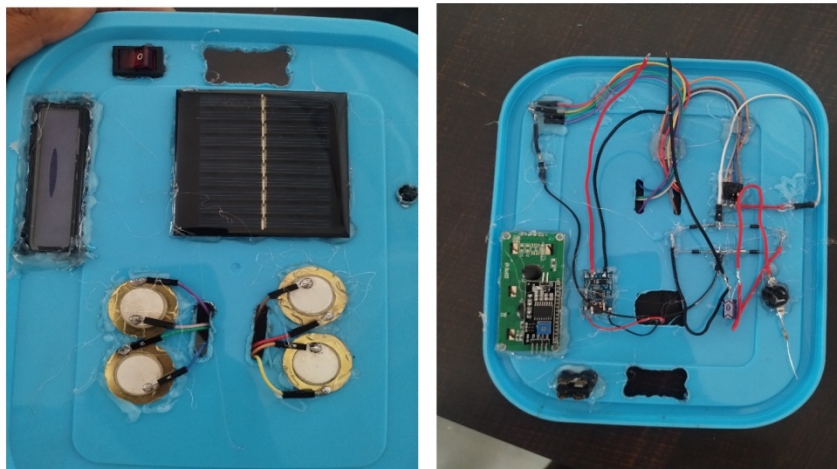

Fig.2.KIT PHOTO

The proposed system operates using relay-based switching controlled by the ESP32 microcontroller. The methodology focuses on controlled energy flow, safe switching between multiple energy paths, and real-time monitoring of system parameters. The system is designed such that only one mode is active at a time, ensuring reliable and conflict-free operation of different energy sources.

1) *Mode Selection:*

The system operates in four distinct modes, which are manually selected by the user through a Bluetooth-based graphical user interface (GUI) on a PC. Each mode corresponds to a specific energy flow path within the system. When a user presses a button in the GUI, a command (M1, M2, M3, or M4) is transmitted wirelessly to the ESP32. The microcontroller interprets this command and activates the corresponding relay configuration. This approach provides flexibility and allows the user to control energy distribution as required.

2) *Relay Control:*

Relay switching is the core mechanism used to control the system. Four relays are connected to the ESP32, and each relay is associated with a specific operation. To ensure safety and avoid short circuits or conflicting connections, only one relay is activated at any given time while all others remain OFF. The operation of each mode is as follows:

Mode 1: Solar energy is connected to the battery through the charging module, enabling battery charging.

Mode 2: The battery is connected to the load, supplying stored energy for consumption.

Mode 3: Piezoelectric energy is routed through a bridge rectifier and stored in a capacitor.

Mode 4: The capacitor is connected to the load, allowing discharge of stored piezoelectric energy.

This relay-based control ensures proper switching and isolation between different sections of the circuit.

3) *Energy Flow Management:*

The system ensures controlled and directed energy flow using relays and proper circuit design. Each energy path (solar, battery, piezo, capacitor, and load) is isolated when not in use. This prevents reverse current flow, energy loss, and potential damage to components. The design guarantees that energy from one source does not interfere with another, maintaining system stability and efficiency.

4) *Voltage Monitoring:*

A DC voltage sensor is used to continuously monitor the battery voltage. The sensor provides analog voltage data to the ESP32, which converts it into a digital value using its ADC. This real-time monitoring helps in assessing battery condition, ensuring it operates within safe limits, and providing useful feedback to the user.

5) *Data Display:*

The system provides real-time feedback through two interfaces:

LCD Display: Displays current mode, battery voltage, and system status locally.

PC GUI: Displays detailed information received via Bluetooth, allowing remote monitoring.

This dual-display system ensures that the user can monitor system performance both locally and remotely.

6) *Bluetooth Communication:*

Bluetooth communication is established between the ESP32 and the PC GUI. The ESP32 acts as a Bluetooth server, receiving commands from the GUI and transmitting system data back. Each button in the GUI sends a specific command (M1–M4), which is processed by the ESP32. The system also sends back real-time voltage and mode information, enabling two-way communication.

7) *Code Logic:*

The control algorithm is implemented in the ESP32 using embedded programming. At system startup, all relays are initialized in the OFF state to ensure safety. The microcontroller continuously checks for incoming Bluetooth commands. When a valid command is received, the system first turns OFF all relays and then activates only the required relay corresponding to the selected mode. Simultaneously, the voltage sensor data is continuously read and processed. The system updates the LCD display and sends the data to the PC GUI at regular intervals. This loop continues, ensuring real-time control and monitoring of the system.

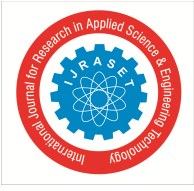

V. RESULTS AND DISCUSSION

The system was tested under all four modes:

Mode Switching:The system successfully switched between modes using the GUI without conflicts.

Energy Storage:Solar panel effectively charged the battery, and piezoelectric discs generated and stored energy in the capacitor.

Monitoring:Voltage readings were accurate and displayed in real-time on both LCD and PC.

Communication:Bluetooth communication between ESP32 and PC GUI was stable.

These results confirm that the system efficiently manages hybrid energy sources and provides reliable control and monitoring.

VI. CONCLUSION

The ESP32-based hybrid energy management system provides an efficient solution for integrating solar and piezoelectric energy sources. The relay-based switching ensures safe and flexible operation across multiple modes. Real-time monitoring and Bluetooth control enhance usability and system performance. This system can be extended for IoT-based smart energy applications, making it a scalable and practical solution for renewable energy management.

VII. ACKNOWLEDGMENT

We would like to express our sincere gratitude to Principal Mr. Vikrant Joshi and Head of Department Ms. Ashwini Khade for giving us the opportunity to present our project. Our heartfelt appreciation goes to our guide, Mr. Siddhesh Desai, for his invaluable guidance, continuous support, and constant motivation throughout this journey. We would also like to acknowledge the contributions of all the departmental faculty members and non-teaching staff for their unwavering support in our learning.

REFERENCES

- [1] Malek, A., et al., "Design and Implementation of Sustainable Solar Energy Harvesting System," *Results in Engineering*, Elsevier, 2023.
- [2] Jettanassen, C., et al., "Development of Piezoelectric Energy Harvesting System for Sustainable Applications," *Sustainability*, MDPI, 2020.
- [3] Juanda, B., et al., "Micropower Design of Energy Harvesting Based on Piezoelectric Transducer Array Circuit," 2024.
- [4] "IoT-Enabled Piezoelectric Energy Harvesting System," *IJRTI Journal*, 2025.
- [5] "Piezo and Solar Based Power Generation and Smart Grid System using ESP32," 2024.



10.22214/IJRASET



45.98



IMPACT FACTOR:
7.129



IMPACT FACTOR:
7.429



INTERNATIONAL JOURNAL FOR RESEARCH

IN APPLIED SCIENCE & ENGINEERING TECHNOLOGY

Call : 08813907089  (24*7 Support on Whatsapp)