



# **iJRASET**

International Journal For Research in  
Applied Science and Engineering Technology



---

# **INTERNATIONAL JOURNAL FOR RESEARCH**

IN APPLIED SCIENCE & ENGINEERING TECHNOLOGY

---

**Volume: 14    Issue: VI    Month of publication: June 2026**

**DOI: <https://doi.org/10.22214/ijraset.2026.83533>**

**[www.ijraset.com](http://www.ijraset.com)**

**Call:  08813907089**

**E-mail ID: [ijraset@gmail.com](mailto:ijraset@gmail.com)**

# Solar-Based E-Waste Sorting Robot

Aditya<sup>1</sup>, Abhishek<sup>2</sup>, Abhijeet<sup>3</sup>, Prasad<sup>4</sup>, Dr. Anuradha Savadi<sup>5</sup>

Department of Electronics and Communication Engineering Sharnbasava University, Kalaburagi

**Abstract:** *Electronic waste (E-waste) is one of the fastest-growing waste streams worldwide. Improper disposal of electronic components leads to environmental pollution and health hazards. Manual sorting of E-waste is time-consuming, inefficient, and exposes workers to harmful materials.*

*This project proposes a Solar-Based E-Waste Sorting Robot that automatically identifies and segregates electronic waste using sensors and robotic mechanisms powered by solar energy. The system utilizes metal detection sensors, infrared sensors, and microcontroller-based automation to classify waste into different categories such as metals, plastics, batteries, and printed circuit boards (PCBs).*

*The robot operates using renewable solar energy, reducing dependency on conventional power sources and promoting sustainable waste management practices. The proposed system improves sorting accuracy, minimizes human intervention, and contributes to efficient recycling processes.*

**Keywords:** *E-Waste Management, Solar Energy, Robotics, Waste Segregation, Arduino, Sensors, Sustainable Technology*

## I. INTRODUCTION

Electronic waste, commonly known as E-waste, refers to discarded electrical and electronic devices such as computers, mobile phones, televisions, batteries, circuit boards, and other electronic equipment. With rapid technological advancements and increasing consumer demand for electronic products, the generation of E-waste has grown significantly worldwide. According to global reports, millions of tons of electronic waste are produced every year, creating serious environmental and health concerns.

Improper disposal of E-waste can release hazardous substances such as lead, mercury, cadmium, and other toxic chemicals into the environment. These harmful materials can contaminate soil, water, and air, posing risks to human health and ecosystems. At the same time, E-waste contains valuable resources such as copper, aluminium, silver, and gold that can be recovered and reused through proper recycling processes. Therefore, efficient collection, segregation, and recycling of E-waste have become essential for sustainable development.

The rapid growth of electronic devices has led to a significant increase in electronic waste generation worldwide. E-waste contains valuable materials such as copper, aluminum, and gold, along with hazardous substances that can harm the environment if not disposed of properly.

Traditional E-waste sorting methods rely heavily on manual labour, which is inefficient and potentially dangerous. Automation in waste management has emerged as a promising solution to improve recycling efficiency and worker safety.

This project presents a Solar-Based E-Waste Sorting Robot that automatically detects and separates electronic waste materials using sensor technologies and robotic mechanisms. The robot is powered by solar energy, making it environmentally friendly and energy efficient.

The proposed system supports sustainable development by reducing landfill waste, enhancing recycling operations, and promoting the use of renewable energy in waste management systems.

The proposed project aims to contribute to smart waste management practices by improving the efficiency of E-waste recycling processes. The system promotes environmental protection, resource conservation, and sustainable technological development. By integrating solar power, sensor technology, and robotics, the project demonstrates a practical approach toward building cleaner and smarter cities.

Furthermore, the project provides an excellent platform for understanding the applications of embedded systems, renewable energy technologies, automation, and environmental engineering.

## II. LITERATURE SURVEY

The increasing generation of electronic waste has become a major environmental challenge across the world. Researchers and industries have been actively working on developing efficient waste management and recycling systems to minimize environmental pollution and recover valuable materials from discarded electronic products.

Various technologies such as automation, robotics, sensor systems, artificial intelligence, and renewable energy have been explored to improve waste segregation processes.

In the early stages, E-waste management mainly relied on manual sorting methods. Workers manually separated metals, plastics, batteries, and electronic components before sending them for recycling. Although effective for small-scale operations, manual sorting was labour-intensive, time-consuming, and exposed workers to hazardous materials. These limitations motivated researchers to develop automated sorting systems.

Several studies introduced sensor-based waste segregation systems capable of identifying different materials using metal detectors, infrared sensors, ultrasonic sensors, and weight sensors. These systems improved sorting accuracy and reduced human involvement. Metal detection technology became particularly useful for identifying ferrous and non-ferrous materials commonly found in electronic waste.

With advancements in embedded systems, microcontroller-based automation became popular in waste management applications. Platforms such as Arduino and Raspberry Pi enabled the development of low-cost and efficient robotic sorting systems. Researchers successfully integrated sensors and actuators to automate waste classification and collection processes. These systems demonstrated higher efficiency compared to conventional manual methods.

Recent research has focused on robotic waste sorting mechanisms. Robotic arms equipped with sensors and conveyor belt systems have been developed to automatically pick and place waste materials into designated containers. Such systems reduce processing time and improve recycling productivity. The use of servo motors and intelligent control algorithms has further enhanced sorting precision.

The proposed Solar-Based E-Waste Sorting Robot addresses these challenges by combining solar energy, sensor-based identification, microcontroller-based control, and robotic automation into a single integrated system.

### III. PROPOSED METHODOLOGY SYSTEM DESIGN

The proposed **Solar-Based E-Waste Sorting Robot** is designed to automate the process of identifying and segregating electronic waste materials using sensor technology, microcontroller-based control, and renewable solar energy. The primary objective of the system is to reduce manual effort, improve sorting efficiency, and promote environmentally sustainable waste management practices.

The system consists of a solar panel, rechargeable battery, Arduino microcontroller, conveyor belt mechanism, metal detection sensor, infrared sensor, servo motors, and multiple waste collection bins. Solar energy serves as the primary power source, making the system energy-efficient and suitable for continuous operation with minimal electricity consumption.

The working process begins when electronic waste items are placed onto the conveyor belt. The conveyor transports the waste materials through the sensing section of the system. During this stage, various sensors analyse the properties of the waste materials. The metal detection sensor identifies metallic components, while the infrared sensor detects non-metallic objects such as plastic casings and electronic boards.

The sensor data is transmitted to the Arduino microcontroller, which acts as the central processing unit of the system. Based on predefined programming logic, the controller determines the category of the detected waste material. Once the classification process is completed, the microcontroller activates the corresponding servo motor mechanism. The servo motor directs the identified waste item into the appropriate collection bin. Metallic waste is separated into one container, while non-metallic components, batteries, and printed circuit boards are directed into their respective bins. This automated segregation process ensures accurate sorting and facilitates efficient recycling.

The entire system is powered using solar energy. The solar panel converts sunlight into electrical energy, which is stored in a rechargeable battery.

#### IV. WORKFLOW DIAGRAM

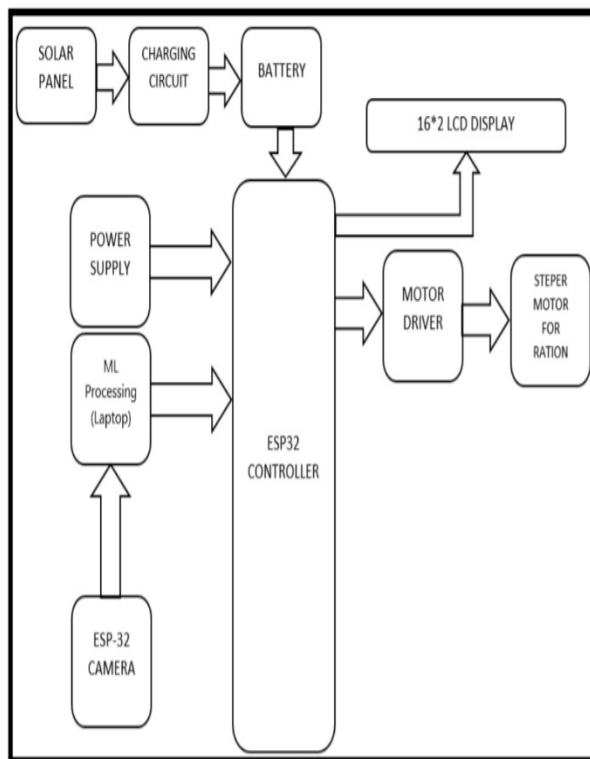

Fig.1.WorkflowDiagram

#### V. IMPLEMENTATION OF THE PROPOSED SYSTEM

The proposed Solar-Based E-Waste Sorting Robot is implemented using a combination of renewable energy technology, embedded systems, sensors, and robotic mechanisms. The system is designed to automatically identify and segregate different categories of electronic waste with minimal human intervention. The implementation focuses on improving sorting efficiency while utilizing solar energy as a sustainable power source.

The hardware implementation consists of a solar panel, rechargeable battery, Arduino Uno microcontroller, metal detection sensor, infrared (IR) sensor, conveyor belt mechanism, servo motors, motor driver module, and waste collection bins. The solar panel captures sunlight and converts it into electrical energy, which is stored in a rechargeable battery. This stored energy powers the entire robotic system, ensuring continuous operation even during low sunlight conditions.

The Arduino Uno serves as the central control unit of the system. It receives input signals from various sensors and processes the collected data according to predefined programming logic. The microcontroller continuously monitors the sensor outputs and makes decisions regarding the classification of waste materials.

The conveyor belt mechanism is used to transport electronic waste items through the sensing section. As the waste moves along the conveyor, the metal detection sensor identifies metallic components such as wires, aluminium parts, and electronic connectors. Simultaneously, the infrared sensor detects non-metallic objects including plastic covers and other insulating materials.

Based on the sensor readings, the Arduino controller categorizes the waste item into its appropriate class. After classification, servo motors are activated to direct the waste material into designated collection bins. Separate bins are provided for metallic waste, plastic waste, batteries, and printed circuit boards (PCBs). This automated sorting process reduces manual labour and increases segregation accuracy.

The software implementation is developed using the Arduino IDE. The control program is written in Embedded C language and uploaded to the Arduino microcontroller.

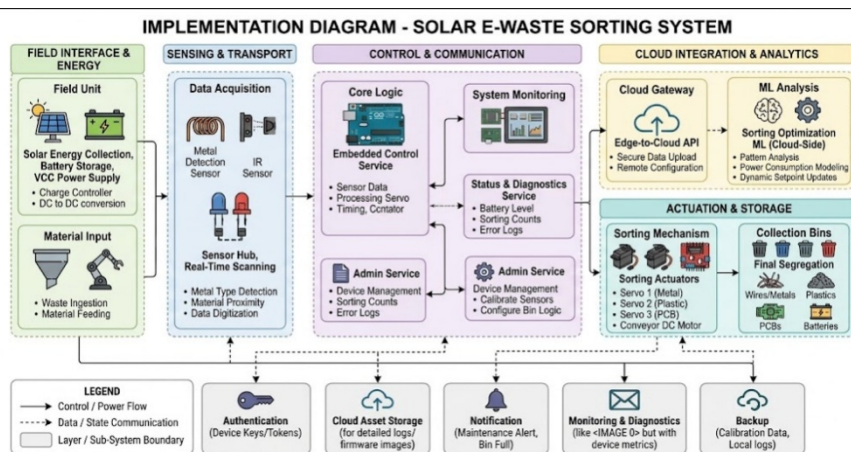

Fig.2. ImplementationDiagram

### System Performance Analysis and Testing

The performance of the proposed **Solar-Based E-Waste Sorting Robot** was evaluated through a series of experiments conducted under different operating conditions. The main objective of the testing process was to analyze the accuracy, reliability, power efficiency, and overall effectiveness of the robotic waste segregation system.

The system was tested using different categories of electronic waste materials, including metallic components, plastic parts, batteries, and printed circuit boards (PCBs). During operation, the conveyor belt transported the waste items through the sensing unit, where the metal detection sensor and infrared sensor identified the material type. Based on the sensor output, the Arduino controller activated the servo motor mechanism to direct the waste into the appropriate collection bin.

Several performance parameters were considered during evaluation. These included sorting accuracy, sensor response time, conveyor operation efficiency, solar power utilization, and battery backup performance. The results indicated that the system was capable of accurately identifying and segregating most E-waste materials with minimal errors.

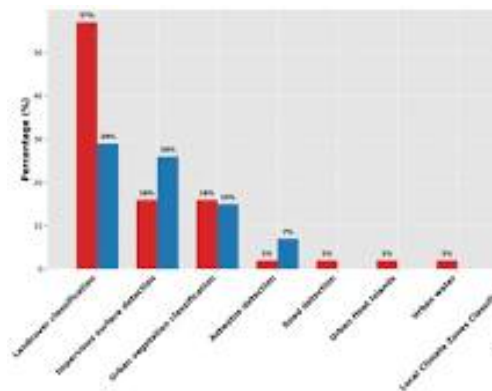

Fig.3.Yolo Model TrainingandValidation PerformanceAnalysis

## VI. RESULTS

The proposed **Solar-Based E-Waste Sorting Robot** was successfully developed and tested to evaluate its performance in the automatic segregation of electronic waste materials. The system was able to identify and separate different categories of E-waste, including metallic components, plastic materials, batteries, and printed circuit boards (PCBs), using sensor-based detection and microcontroller-controlled automation. During the testing phase, multiple electronic waste samples were placed on the conveyor belt and passed through the sensing unit. The metal detection sensor accurately identified metallic objects, while the infrared sensor effectively distinguished non-metallic materials. Based on the sensor inputs, the Arduino controller activated the servo motor mechanism to direct each waste item into its corresponding collection bin. The experimental observations indicate that the robot achieved a high level of sorting accuracy and demonstrated stable operation under solar-powered conditions. The conveyor system operated smoothly without interruptions, and the servo motors responded accurately to classification commands. The rechargeable battery provided sufficient backup power, enabling continuous operation even during periods of reduced sunlight.



Fig.4.Experimental Setup of Solar-Based E-Waste Sorting Robot

The above figure shows the developed Solar-Based E-Waste Sorting Robot Prototype. The system is designed to automatically identify and segregate different types of electronic waste using sensor-based detection and renewable solar energy.

The prototype consists of a solar panel, a sorting mechanism with collection bins, a sensor module, a microcontroller-based control unit, and a monitoring interface displayed on a laptop. The solar panel provides electrical energy to operate the system, making it environmentally friendly and energy efficient.

When an electronic waste item is placed into the input section, sensors detect the material characteristics. Based on the sensor readings, the microcontroller processes the information and activates the sorting mechanism. The waste item is then directed into the appropriate collection bin. The cylindrical containers shown in the figure act as separate storage bins for different categories of waste materials.

The laptop interface is used for monitoring system operation and displaying sensor outputs or classification results. The setup demonstrates the integration of renewable energy, embedded systems, and automation technologies for efficient E-waste management.

Components Visible in the Figure (Fig .4)

- Solar Panel – Supplies renewable energy to the system.
- Sorting Bins – Collect separated waste materials.
- Sensor Module – Detects the type of waste material.
- Servo Motor Mechanism – Controls waste diversion.
- Microcontroller Unit (Arduino) – Processes sensor data and controls operations.
- Laptop Interface – Displays monitoring and system status information.
- Sample Waste Objects – Demonstrate sorting of metal and plastic materials

## VII. CONCLUSION

The proposed **Solar-Based E-Waste Sorting Robot** successfully demonstrates an efficient and sustainable approach for the automated segregation of electronic waste. The system integrates renewable solar energy, sensor technology, embedded control systems, and robotic mechanisms to classify and separate different categories of E-waste with minimal human intervention.

The robot utilizes metal detection and infrared sensors to identify various waste materials and automatically directs them into designated collection bins. The experimental results indicate that the system achieves high sorting accuracy while maintaining reliable performance under solar-powered operation. The use of solar energy reduces dependence on conventional electricity sources, making the system environmentally friendly and cost-effective.

The developed prototype provides an effective solution to the growing challenge of electronic waste management by improving recycling efficiency, reducing manual labour, and minimizing human exposure to hazardous materials. The automated sorting process ensures proper segregation of recyclable components, thereby supporting resource recovery and environmental conservation.

### VIII. FUTURESCOPE

The proposed **Solar-Based E-Waste Sorting Robot** provides an effective solution for automated electronic waste segregation. However, there are several opportunities for future improvements that can enhance the system's efficiency, intelligence, and practical applicability in large-scale waste management environments.

One of the major future enhancements is the integration of **Artificial Intelligence (AI)** and **Machine Learning (ML)** techniques for advanced waste classification. By incorporating cameras and image-processing algorithms, the system can identify a wider range of electronic waste components with greater accuracy and automatically adapt to new types of waste materials. The system can also be upgraded with **Internet of Things (IoT)** technology, enabling real-time monitoring and remote control through cloud platforms. IoT integration would allow users to track system performance, monitor bin capacity, receive maintenance alerts, and access operational data from any location. Future developments may include the use of a **robotic arm** for automated picking and placement of waste items. This would improve sorting precision and make the system suitable for industrial-scale recycling facilities. Advanced sensors capable of identifying different metals, batteries, and hazardous materials can also be incorporated to improve segregation quality.

### REFERENCES

- [1] Waste Electrical and Electronic Equipment (WEEE) Handbook, V. Goodship and A. Stevels, *Waste Electrical and Electronic Equipment (WEEE) Handbook*, Woodhead Publishing, 2012.
- [2] United Nations Environment Programme, *Global E-Waste Monitor Report*, United Nations University, Geneva, Switzerland, 2024.
- [3] Institute of Electrical and Electronics Engineers, "Smart Waste Management Systems Using IoT and Robotics," IEEE Conference Proceedings, 2021.
- [4] Arduino IDE Documentation, Arduino Official Documentation, 2025.
- [5] Robotics and Automation Applications in Waste Segregation Systems, *International Journal of Engineering Research and Technology (IJERT)*, Vol. 10, Issue 5, 2021.



10.22214/IJRASET



45.98



IMPACT FACTOR:  
7.129



IMPACT FACTOR:  
7.429



# INTERNATIONAL JOURNAL FOR RESEARCH

IN APPLIED SCIENCE & ENGINEERING TECHNOLOGY

Call : 08813907089  (24\*7 Support on Whatsapp)