



# IJRASET

International Journal For Research in  
Applied Science and Engineering Technology



---

# INTERNATIONAL JOURNAL FOR RESEARCH

IN APPLIED SCIENCE & ENGINEERING TECHNOLOGY

---

**Volume:** 14    **Issue:** IV    **Month of publication:** April 2026

**DOI:** <https://doi.org/10.22214/ijraset.2026.82091>

[www.ijraset.com](http://www.ijraset.com)

Call:  08813907089

E-mail ID: [ijraset@gmail.com](mailto:ijraset@gmail.com)

# Study on Hydro Mechanical Forming Technology

Dr. K. C. Sabitha

Assistant Professor Dept.of Mechanical Engineering, Mahatma Gandhi Institute of Technology Gandipet, Hyderabad - 500075

**Abstract:** Sheet hydroforming is one of the sheet metal forming processes used in industry to produce complex shapes with high limiting drawing ratio. In sheet metal hydroforming, controlled metal flow during the operation minimizes localized stress concentrations that may cause workpiece buckling or wrinkling. Sheet metal hydroforming is slower than traditional stamping, thus its use is limited to short runs of more highly specialized parts. Hydroforming is an unconventional processes of the metal forming that are used for forming metal sheet and tube thin walled elements, as other spatial elements. Technological forming processes by fluid are deep drawing, stretching, bending, extruding, tube forming. Hydroforming and other actions of plastic forming are based on the laws of plastic theory, balance of forces that are opposite to deformation. The success of hydroforming action depends on the processing parameters are forming force, the force of sheet metal holder, the frame, dimensions of workpiece and friction. Hydroforming analysis at the plasticity area is possible because of actual knowledge application on deformation processing for conventional or unconventional processing as the values of individual parameters can be compared. The fluid pressure intensification pressure system consists of a low-pressure, high flow rate filling system, along with a high pressure intensifier to raise the fluid pressure to forming levels. The forming fluid is water based and contains additives such as lubricants, drying agents and rust preventatives. In this paper presents hydromechanical forming processes.

**Keywords:** Fluid Pressure, hydromechanical forming, sheet hydroforming, deep drawing.

## I. INTRODUCTION

Plastic material forming depends on the process kind and forming regime. Long ago here was an understanding that plastic forming of sheet metal elements is made by hard tools over 1000 pieces. By occurring of unconventional processes such as hydro forming, the same element can be made by one or by another method(1-2). The choice of technology process depends on the analysis of influencing process parameters of sheet metal forming. The way of fluid forming is classified into the process of hydro mechanical forming and hydro forming. At hydro mechanical forming, the forming of final piece is defined by hard tool since the strain force is achieved by fluid. At hydro forming, impressed fluid is the carrier of strain force since the form is defined by cast geometry(3). According to classical drawing out, where there is contact between the tool and working piece, at hydro forming the presence of un pressed fluid between metal sheet and the tool prevents the surface of metal sheet from damaging so the parts with quality outside surface or the parts with protection and with covering of outside surface can be made. In this way the form and part dimension accuracy is increased, and total drawing out stresses are decreased.

Hydroforming uses fluid pressure applied to a tubular or sheet metal blank to form it into the desired component shape(4). The most commonly used materials in hydroforming include the various grades of steel. These grades of steel are used extensively because they exhibit good fatigue properties, high energy absorption, and reasonable resistance to corrosion. Other metals used for hydroforming include stainless steels, aluminum, copper and copper alloys. All hydroforming systems include tooling and dies, a hydraulic press and a fluid pressure intensification system. Hydroforming dies vary dramatically with regards to sheet metal hydroforming and tubular hydroforming operations. Dies may be single or multi-cavity. Hydroforming utilizes hydraulic, rather than mechanical, presses for many reasons. Hydraulic presses are able to deliver full tonnage at any point in the stroke, not just at the bottom as is the case with mechanical presses(5). The hydraulic press can be adjusted to provide optimal part clearance. Also, hydraulic presses can be stopped in mid-stroke which is advantageous to some hydroforming operations. Sheet metal forming by fluid under pressure is applied in deep drawing, stretching of sheet, hydroforming of welded sheets, hydroformig with metal heating. The basic tendencies of development of sheet metal forming process by fluid under pressure are improvement of sheet deformability, improvement of tribological forming conditions, optimization of forming process, development of new forming processes and new materials, automation of forming process, application of flexible tools, and implementation of flexible and intelligent systems (6-8). In a typical hydroforming operating cycle, a blank is placed on the lower die tooling, and the press is closed. Fluid is then introduced to either one side of the sheet metal blank, or within the tubular blank. As fluid pressure is intensified the blank deforms, taking the shape of the tooling. Lubrication is especially important in hydroforming. Lubricants assist in reducing the friction and stresses as the metal flows into its final shape.

Hydro forming is technology which is based on influence of fluid under high pressure to the inner or outer side of workpiece wall. Implementation success of hydroforming process depends of a correct election of: die, material, fluid pressure and other process parameters. Hydroforming process should be implemented by using optimal parameters of the forming process that would allow stable and successful hydroforming process.(9-11).In recent years,increasing attention has been focused on hydroforming technology due to the rapid development of automobile production and the aerospace industry (12). Many methods of sheet hydroforming have been proposed to meet practical and theoretical applications, such as hydromechanical deep drawing (13), hydrodynamic deep drawing (14), aquadraw process (15), and hydroforming deep drawing (16).

## II. SHEET HYDRO MECHANICAL FORMING PROCESSES

Sheet hydroforming process is an alternative to drawing process where either punch or die is replaced by hydraulic medium, which generates the pressure and forms the part. Sheet hydroforming is classified into two types Sheet HydroForming with Punch (SHF-P) and Sheet HydroForming with Die (SHF-D). In SHF-P (Fig.1(a)), the hydraulic fluid is replaced with the die, while in SHF-D (Fig.1(b)), the hydraulic fluid is replaced with the punch. Absence of either punch or die in SHF process reduces the tooling cost (17).

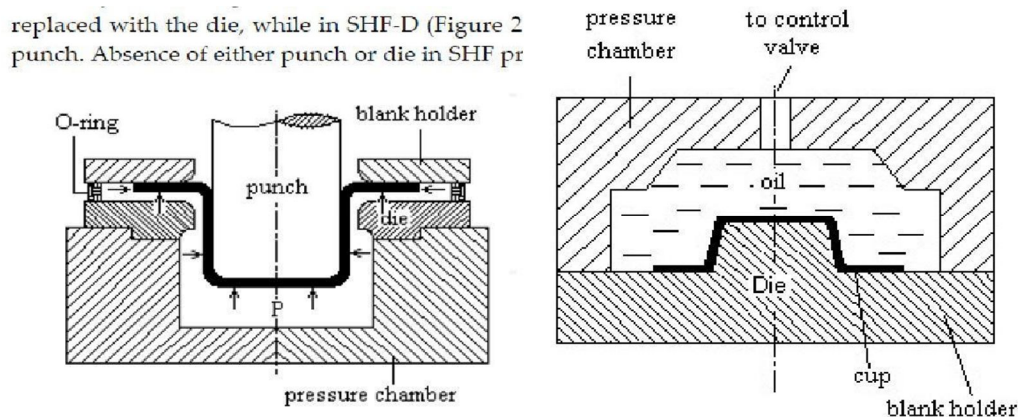

Fig. 1. Schematic of the sheet hydroforming process: (a) SHF-P, (b) SHF-D [17]

Some new sheet hydroforming processes have been introduced during the last few years and also studied the standard hydroforming process (18-20). Fig.2 illustrates the tool set-up for this process. An essential part of this set-up is a rubber diaphragm that seals the liquid in the pressure chamber. During the process, the flange of the part is kept pushed against the blank holder by the fluid pressure transmitted through the diaphragm. There are many advantages for the standard hydroforming process, such as better surface quality and forming of complex shapes. Meanwhile, it has some disadvantages, such as the requirement of heavy presses. In addition, it is easy to destroy the rubber diaphragm, since the diaphragm is nearly under a similar deformation as the workpiece(18).The fluid pressure is very important in this process, because wrinkles will appear if the pressure is not sufficiently high. If the pressure is too high, the blank may be damaged by rupture (20).The hydromechanical deep drawing process has been developed by researchers on the basis of the standard hydroforming technology (18-20).Fig.3(a) shows the schematic illustration of this process. The fluid pressure in this process can be produced by the downward movement of the punch, or be supplied by a hydraulic system, since no rubber diaphragm is used. The tool device in this process is similar to that in a conventional deep drawing. An O-ring is used to prevent the flow out of the fluid on the flange. By using this process, more local deformation, increased drawing ratio and forming of complicated parts are realized (18). But, in this method the blank holder force is not sufficient to prevent complex shapes from wrinkling. In addition, the fluid pressure is very high that causes high clamping force, and thus, heavy presses are required.

The hydromechanical deep drawing process has been developed as the radial hydromechanical deep drawing (hydro-rim) process (Fig.3(b)) (21). In this process, when the punch goes down into the die cavity, the blank is forced into the die cavity filled with liquid. The liquid will be pressurized and will push the blank tightly on the punch surface.Also, the liquid pressure exists around the blank rim. This, in turn, can realize some forced radial feeding which is difficult in the current sheet hydroforming processes. In this method, since there is no clamping force (with rigid or semi-rigid part), wrinkling will occur easily in the forming of complex shapes.In hydro forming an active-elastic blank holder system for high-pressure forming(22-23).

Fig.4 illustrates the simplified schematic of this system. In this method, an elastic blank holder with a circular groove was used under the blank. The active-elastic blank holder system showed improvements with respect to the material flow in the flange area and reduced sheet thinning in critical corner regions of the workpiece. In this method the die set-up is complicated and the forming pressure is high. Among the sheet hydroforming processes, hydrodynamic deep drawing assisted by radial pressure (HDDRP) has been used to form complex shapes and has a good drawing ratio (24). This process is shown in Fig.5.

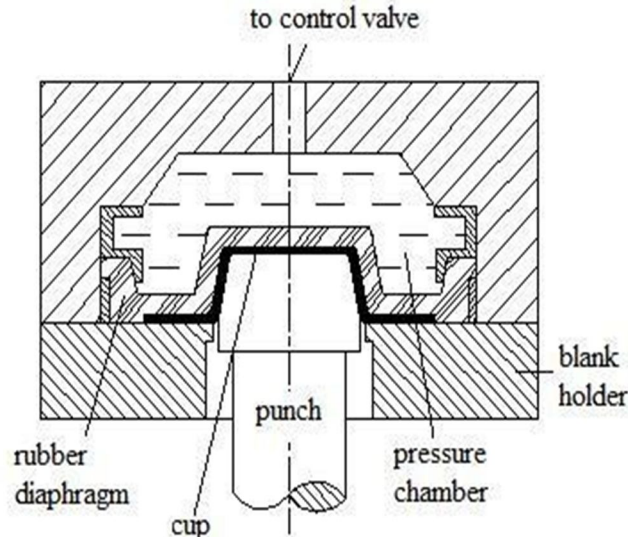

Fig.2 Tool set-up for standard hydroforming (17)

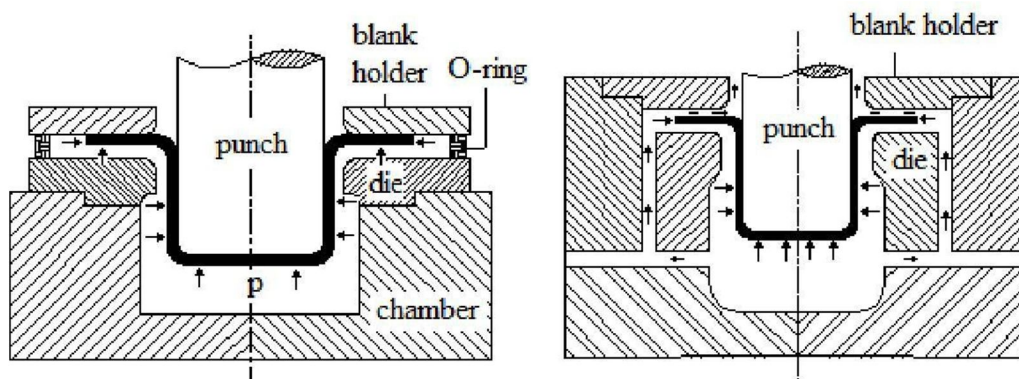

Fig.3 Tool set-up for: (a) hydromechanical, (b) hydro-rim, deep drawing process (17)

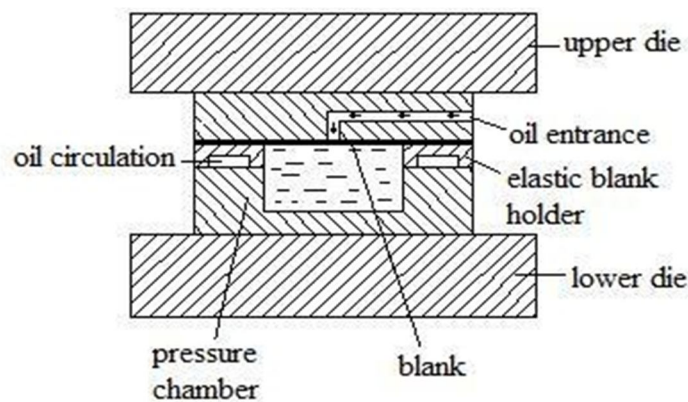

Fig.4 A simplified schematic of tool set-up for active-elastic blank holder system (1)

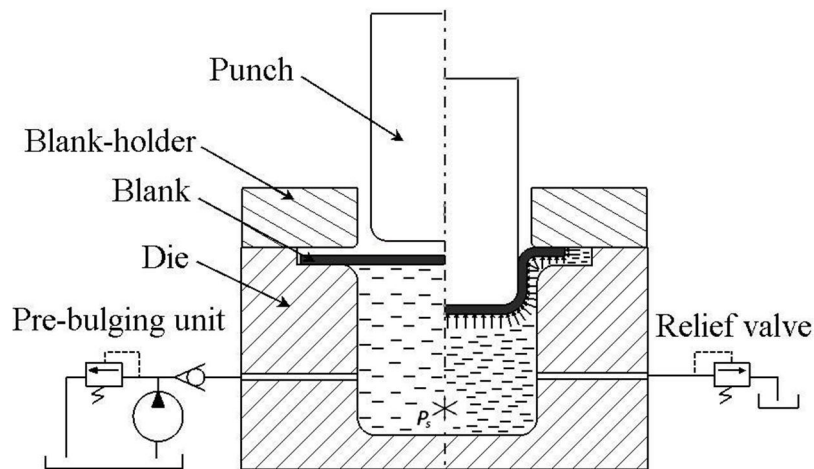

Fig.5 A simplified schematic of tool set-up for hydrodynamic deep drawing (24)

### III. COMPARING OF CONVENTIONAL AND HYDRO MECHANICAL FORMING

Comparing the conventional forming actions with hydro mechanical forming there can be noticed the differences.

- 1) tools
- 2) tribology of producing process
- 3) product quality
- 4) producing technology
- 5) machining systems

The compared values of individual parameters either at conventional or unconventional processes can be obtained by theoretical or experimental ways. Hydro mechanical forming process conditions influence on the quality of processed surface significantly that gives better quality than classical processes(20).

Comparison of process parameters of conventional and hydro mechanical forming of metal sheet. In general compared the following process parameters.

- 1) stand at the contact surface
- 2) process distortion force
- 3) stress-strain stand
- 4) strain work
- 5) tribology stand
- 6) process quality and stability
- 7) tool worn-out and existence
- 8) product geometry

### IV. HYDROFORMING OF METAL BY HEATING

In order to increase the deformability of aluminum and magnesium alloys heating of workpiece before hydroforming process starts is performed (25). Temperature influence to hydroforming process for results has enhancing the ability of metal forming. Fig. 6 shows an example of temperature influence (150°C, 200°C i 250°C) to part forming ability .

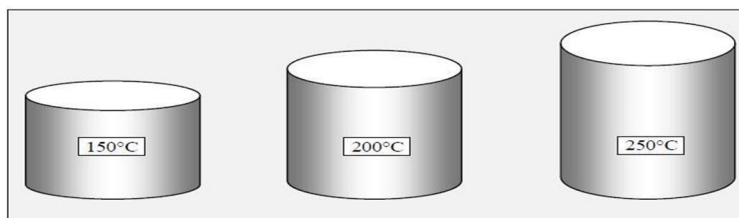

Fig. 6. Parts formed by heated Hydroforming [25]

Application of magnesium alloys is significant for electro industry (digital cameras, computers, mobile telephone apertures parts, etc.).

### V. RESULTS AND DISCUSSION

Hydromechanical drawing is used in fabricating large sheet metal panels and can improve the buckling strength of the finished part. The lower blankholder is a reservoir containing an oil and water emulsion as a fluid medium, while the top die holds the punch. As the press closes over the blank it forms a water tight seal between the die halves. At this stage, a part-specific gap exists between the clamped blank and the punch. As soon as the blank-holding force has built, the fluid is brought to a defined pressure. This pressure causes a controlled bulging of the blank over its entire surface, resulting in work hardening of the workpiece and a substantial improvement in buckling strength of the part. Bulging continues until the blank comes to rest against the center of the punch surface. After this pre-stretching process, the punch is lowered into the blank. The sheet metal flows rather than rubs against the punch and female die by fluid pressure. Hydromechanical drawing is cost effective since only one die half needs to be machined to achieve the required part shape.

Fig.7 illustrates the force-punch stroke curve that resulted from the FE simulation and experimental results for the two drawing ratios of  $\beta = 2$  and  $\beta = 2.43$  reported(26-27). As shown in the graph, in order to verify these results, they were compared with the two specific experimental results reported(26-27)., namely, aluminum cups with diameters of 70 and 85 mm (i.e. drawing ratios of  $\beta = 2$  and  $\beta = 2.43$ ) and 1.5 mm in thickness (26-27).The trends demonstrated in the simulation and experimental results indicated acceptable conformity.

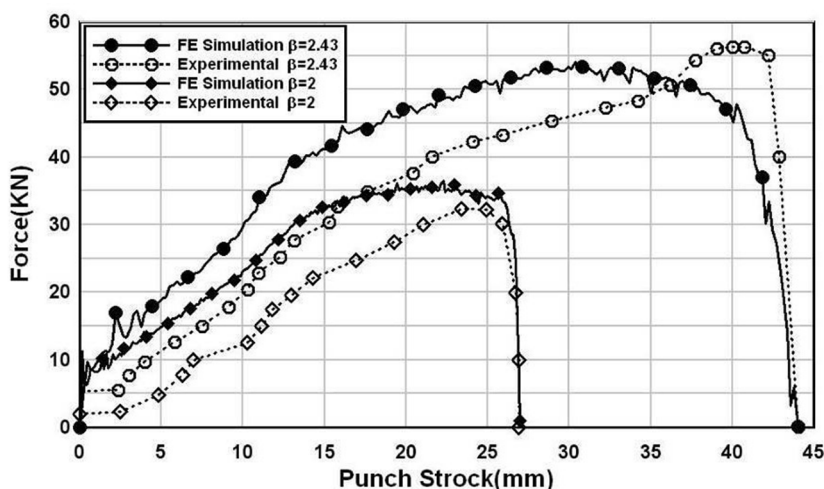

Fig. 7 Force- punch stroke curves obtained from simulation and those of experiments(26-27).

In order to investigate pressure of fluid distribution in hydromechanical forming, the effect of decreasing pressure from B to C, a pressure path was selected in which there was no change in pressure from B to C (Fig. 8a). This pressure path is shown as path 1. Sheet thickness distributions of two different pressure paths showed that path 1 resulted in more variations in thickness(27). This confirmed that original decrease in the pressure from B to C yielded a better distribution as shown in Fig. 8b.

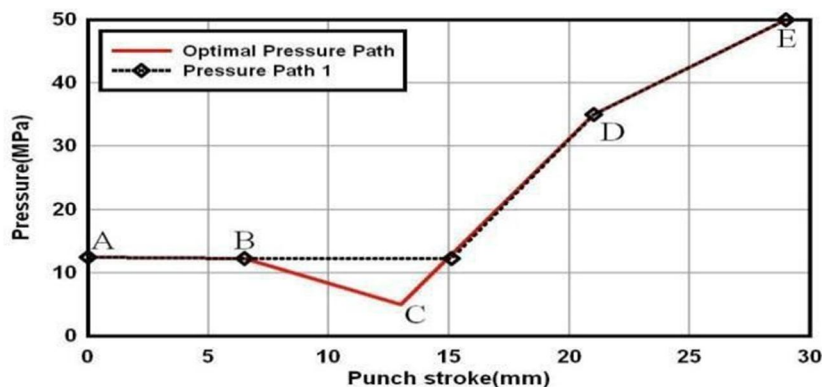

Fig 8.(a) Pressure path 1(27)

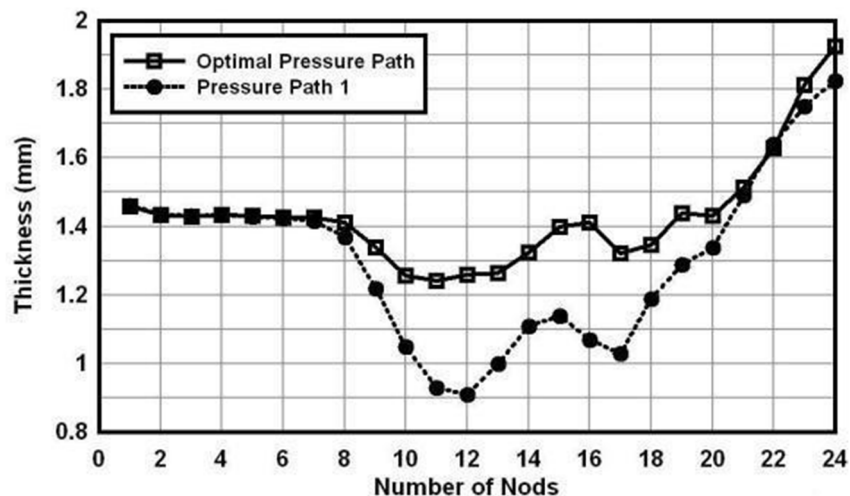

Fig. 8 (b) sheet thickness distribution(27)

## VI. CONCLUSIONS

In the last decades unconventional processing substitutes the conventional processing actions. Though the fluid processing is applied since 70' years theoretical or experimental research of it is still necessary. In the developed countries hydroforming is increasing 5-10% per year to compare with classical plastic processing. The given advantages, allow automation and action optimization what the top of plastic forming processes make hydroforming. The plastic material forming processes by hydroforming has defined its advantages and applications. The following are obtained from hydromechanical forming methodology.

- 1) Decreasing of operations number, in one step it is made deep drawing out and engraving of different forms and needed hole boring
- 2) Simple tool production and the possibility of different thickness metal sheet parts production with the same tool
- 3) Cheap tool, because it is made by half of hard tools, and the other part of tool is fluid
- 4) More betterment tribology, lower contact friction
- 5) Obtaining quality inside part surface, because only outside part surface touches hard ring of drawing out
- 6) Possibility of complex larger dimensions element production (car industry, ship building, military equipment)
- 7) Economy increasing, because it is possible to produce parts of different forms and dimensions that at the same tool cast changing at the defined size frames is made
- 8) Make parts, which are not possible to produce by classical processes

The Justification of the application hydroforming process is in advantages and characteristics which this process offers compared to the classical processes of sheet forming. Quality of product is higher compared to the classical methods, because tribological conditions of plastic forming are significantly better. Process is demanding, tools are cheap, material utilization is better, possibility of automation and application to wide variety of products. Hydroforming is used for forming parts by metal sheets and tubes, larger dimensions and complex geometrical shapes.

## REFERENCES

- [1] Jurkovic, M., Mamuzic, I., Karabegovic, E.: The plastic forming of sheet of metal with unpressed fluid, Journal Metallurgy, vol.43, br.4, pp.265-348, Zagreb, 2004.
- [2] Nakamura, K., Nakagawa, T. Sheet metal forming with hydraulic counter.-Pressure in Japan, Annals of the CIRP, 1, 1987, p.191-194.
- [3] Siegert, K. and all. Sheet metal hydroforming.-Proc. of TPR 2000, Cluj-Napoca, 2000.
- [4] D. Banabic, T. Balan, D.S. Comsa., Closed-form solution for bulging through elliptical dies, Journal of Materials Processing Technology, 115, 1, pp.83-86, 2001.
- [5] D. Banabic, M. Vulcan, Bulge testing under constant and variable strain rates of superplastic aluminium alloys, Annales of CIRP, 54, 1, pp. 205-209, 2005.
- [6] S. Yossifon, J. Tirosh, Rupture instability in hydroforming deep-drawing process, International Journal of Mechanical Sciences, 27, 9, pp. 559-570, 1985.
- [7] Y. Aue-U-Lan, G. Ngaile, T. Altan, Optimizing tube hydroforming using process simulation and experimental verification, Journal of Materials Processing Technology, 146, 1, pp. 137-143, 2004.
- [8] Jurković, M., Mamuzić, I., Karabegović, E. The plastic forming of sheet of metal with unpressed fluid.-Metallurgy, 2004, v.43(4), p.323-327.
- [9] Jurković, Z., Jurković, M. Modeling and optimization of the tool geometry for deep drawing of sheet metal. - Metallurgy, 39, 2000, 4, p.231-236.
- [10] Bakhshi-Jooybari M, Elyasi M, Gorji A (2009) Numerical and experimental investigation of the effect of the pressure path on forming metallic bellows. Proc. IMechE, Part B: J.Engineering Manufacture. 224: 95-101.



- [11] Elyasi M, Bakhshi-Jooybari M, Gorji A, Hossinipour SJ, Norouzi S (2008) Numerical and experimental investigation on forming metallic bellows in closed and open die hydroforming. *Steel Research International*. 79: 148–154.
- [12] M. Koç, A. Agcayazi, J. Carsley, An experimental study on robustness and process capability of the warm hydroforming process, *Journal of manufacturing science and engineering*, 133, 2, pp. 481–488, 2011.
- [13] J. Lin, S.D. Zhao, Z.Y. Zhang, Z. Wang, Deep drawing using a novel hydromechanica tooling *Inter. Journal of Machine Tools and Manufacture*, 49, 1, pp.73–80, 2009.
- [14] D. Kang, L. Lang, X. Meng, J. Xuan, A study on hydrodynamic deep drawing equipment, *Journal of Materials Processing Technology*, 101, 1–3, pp. 21–24, 2000.
- [15] K.B. Nielson, M.R. Jensen, J. Danckert, Optimization of sheet metal forming processes by a systematic application of finite element simulations, Second European LS-DYNA Users Conference, Goteburg, Sweden, 1999, A3–A16.
- [16] A. Kandil, An experimental study of hydroforming deep drawing, *Journal of Materials Processing Technology*, 134, 1, pp. 70–80, 2003
- [17] Hosseinzade M, Mostajeran H, Bakhshi-Jooybari M, Gorji A, Norouzi S, Hossinipour SJ (2009) Novel combined standard hydromechanical sheet hydroforming process, *IMEchE Journal of Engineering Manufacture*, 224: 447-457.
- [18] Thiruvarduchelvan S, Lewis W (1999) A note on hydroforming with constant fluid pressure. *J. Mater. Process. Technol.*, 88: 51-56.
- [19] Kandil A (2003) An experimental study of hydroforming deep drawing. *J. Mat Mater.Process. Technol.* 134: 70-80.
- [20] Zhang SH, Danckert J (1998) Development of hydro-mechanical deep drawing. *J. Mater.Process. Technol.* 83: 14 – 25.
- [21] Tirosh J, Shirizly A, Ben-David D, Stanger S (2000) Hydro-rim deep-drawing processes of hardening and rate-sensitive materials. *Int. J. Mech. Sci.* 42: 1049-1067.
- [22] Groche P, Metz C (2006) Investigation of active-elastic blank holder systems for highpressure forming of metal sheets. *Int. J. Mach. Tools Manufact.* 46: 1271–1275.
- [23] Groche P, Metz C (2005) Hydroforming of unwelded metal sheet using active-elastic tools. *J. Mater. Proc. Tech.* 168: 195-201
- [24] Lang L, Danckert J, Nielsen KB (2004) Investigation into hydrodynamic deep drawing assisted by radial pressure Part I. Experimental observations of the forming process of aluminum alloy. *J Mater Process Technol* 148:119-131.
- [25] H. Choi, M. Koc, J. Ni, Determination of optimal loading profiles in warm hydroforming of lightweight materials, *Journal of Materials Processing Technology*, 190, 1–3, pp. 230–242, 2007.
- [26] A. Kandil, An experimental study of hydroforming deep drawing, *Journal of Materials Processing Technology*, 134, 1, pp. 70–80, 2003.
- [27] Asghar shamsi sarband, et al., Optimization of the pressure path in sheet metal hydroforming, *Proceedings of the romanian academy, series A*, Vol 13, Number 4 (2012), pp.351-359



10.22214/IJRASET



45.98



IMPACT FACTOR:  
7.129



IMPACT FACTOR:  
7.429



# INTERNATIONAL JOURNAL FOR RESEARCH

IN APPLIED SCIENCE & ENGINEERING TECHNOLOGY

Call : 08813907089  (24\*7 Support on Whatsapp)