



iJRASET

International Journal For Research in
Applied Science and Engineering Technology



INTERNATIONAL JOURNAL FOR RESEARCH

IN APPLIED SCIENCE & ENGINEERING TECHNOLOGY

Volume: 7 Issue: 1 Month of publication: January 2019

DOI: <http://doi.org/10.22214/ijraset.2019.1002>

www.ijraset.com

Call:  08813907089

E-mail ID: ijraset@gmail.com

“Survey on IOT based Air and Sound Pollution Monitoring System”

Dennis Menezes¹, Nachiket Waikos², Zameer Khazi³, Manish Jha⁴, Assistant Prof. Kanchan Wankhade⁵

^{1, 2, 3, 4, 5}Department of Computer Engineering, Dhole Patil College of Engineering, Pune, India

Abstract: Presently multi day in metropolitan urban areas air and noise pollution winds up significant issues, because of high decibels and lethal gases present in the earth which specifically impact on human wellbeing and subsequently needs an uncommon consideration. In this manner, it has now turned out to be important to control the pollution (air and noise) to guarantee solid employment and better future. In this paper, a powerful usage for Internet of Things is utilized for observing air states of condition like air pollution and sound pollution. This paper displays an applied design for an adaptable, adaptable and cost effective for checking the air and sound nature of a specific site. This framework proposes an air quality and in addition sound pollution observing framework that enables us to screen and check live air quality and sound pollution in a region through IOT. Framework utilizes air sensors to detect nearness of hurtful gases/mixes noticeable all around and continually transmit this information. Likewise, framework continues estimating sound dimension and reports it.

Keywords: Sound level, Gases, IOT, Pollution, Sensor

I. INTRODUCTION

In this paper System utilizes air sensors to detect nearness of destructive gases/mixes noticeable all around and continually transmit this information. Additionally, framework continues estimating sound dimension and reports it. The sensors interface with raspberry pi which forms this information and transmits it over the application. This enables experts to screen air pollution in various territories and act against it. Likewise, experts can keep a watch on the commotion pollution close schools, healing facilities and no sounding territories, and if framework identifies air quality and sound issues it alarms specialists so they can take measures to control the issue. Some future buyer applications imagined for IOT seem like Wi-Fi, however a portion of the more functional and reasonable sounding potential outcomes for the innovation include: Receiving admonitions on your telephone or wearable gadget when IOT systems recognize some physical threat is identified close-by. System Devices and the Internet of Things all sorts of standard family unit gadget scan are adjusted to working an IOT framework. Wi-Fi organize connectors, movement sensors, cameras, amplifiers and other instrumentation can be installed in these gadgets to empower them for work in the Internet of Things. Home computerization frameworks as of now actualize crude renditions of this idea for things like lights; in addition to different gadgets like remote scales and remote circulatory strain screens that each speaks to early instances of IOT devices.

II. LITERATURE SURVEY

The air and sound pollution monitoring system is absolutely important for detecting wide range of gases, also sensors have long life time, easily available, less cost, easy to handle and are compact. Quality of air can be checked indoor as well as outdoor. This system has simple drive circuit, works on real time and has visual output. The main objective of this paper is to ensure that the air and sound pollution is monitored and kept in control by taking measure accordingly. The proposed paper have certain limitations regarding humidity which should be less than ninety-five percent and exact measurement of contaminating gases cannot be detected in ppm. This paper can be used for monitoring pollution level and also to prevent excess of pollution which can cause huge problem in future. This paper gives an idea on how user can give instant alert to the authorities. The cost effective IOT technology is used. Hence air and sound pollution is monitored by using this technology. [1]

The motive of making a smart city can be fulfilled by using technology, thus making the life better and also enhancing the quality of services, therefore meeting every individual's needs. With modern technology in fields of information and communication, it has become easy to interact with the authorized people of city to tell them where about of the area or city, how well the city is developing and how to make it possible to achieve a better life quality. In this system, an application was created to make one more step in the fulfillment of the goal. An area is analyzed for evaluating how much pollution is affecting the area. The components of gases and their amounts are calculated and checked. If the amount is higher than normal then the officials are reported about it. After that the people are made to clear the area and taken to a safe place. The combined network architecture and the

interconnecting mechanisms for the accurate estimation of parameters by sensors is being explained and delivery of data through internet is presented. [8] The Automatic Air & Sound management system is a step forward to contribute a solution to the biggest threat. The air & sound monitoring system overcomes the problem of the highly-polluted areas which is a major issue. It supports the new technology and effectively supports the healthy life concept. This system has features for the people to monitor the amount of pollution on their mobile phones using the application. So, it becomes very reliable and efficient for the Municipal officials along with the Civilians to monitor environment. Letting civilians also involved in this process adds an extra value to it. As civilians are now equally aware and curious about their environment, this concept of IOT is beneficial for the welfare of the society. And it is implemented using the latest technology. [2] This IOT based air and noise pollution monitoring device is a great step towards a healthy livelihood. With the help of this device not only the municipal authorities but even the common people can participate in the process of controlling pollution and ensure safe environment. These automatic devices, once installed are capable of continuously tracking the pollution level and analyze the detected information. The most highlighting feature of this device is that the output is represented in digital as well as analog format with the help of a simple mobile application which is usable on all android devices like smart phones, tablets, PDA's etc. The device itself is very eco-friendly and does not harm the environment in any way. Moreover, it is based on one of the modern technology and also inexpensive as compared to other technologies developed so far and can be installed anywhere. [3] For creating the system, first author did the research based on the system about IOT and various sensors. Sensors of air and sound based on availability and economical price were selected. For the interaction of internet with the system using a Wi-Fi module which is connected to the microcontroller through the serial port. So, the measured data is sent from the module to any location with its range from the data can be fetched using a laptop /mobile. [4] The Automatic Air & Sound management system is a step forward to contribute a solution to the biggest threat. The air & sound monitoring system overcomes the problem of the highly-polluted areas which is a major issue. It supports the new technology and effectively supports the healthy life concept. This system has features for the people to monitor the amount of pollution on their mobile phones using the application. To implement this need to deploy the sensor devices in the environment for collecting the data and analysis. By deploying sensor devices in the environment, system can bring the environment into real life i.e. it can interact with other objects through the network. Then the collected data and analysis results will be available to the end user through the Wi-Fi. The data can be an important source when addressing the issue of the impacts of motorcycles at idles (e.g. waiting for a green light) on air quality. Moreover, to achieve real-time monitoring, the data of CO concentration in a particular place could be reviewed from mobile communication devices, such as PDAs, smart phones, and tablet PCs to help keep air quality in check. [5]

III. PROBLEM DEFINATION

- A. Air and sound pollution is a developing issue nowadays. It is important to screen air quality and monitor it for a superior future and sound living for all.
- B. Here framework propose an air quality and also solid pollution observing framework that enables us to screen and check live air quality and sound pollution specifically territories.

IV. PROPOSED SYSTEM

This framework is made to satisfy the reason and need of the general public to screen and check the live air quality and sound pollution in a region through IOT.

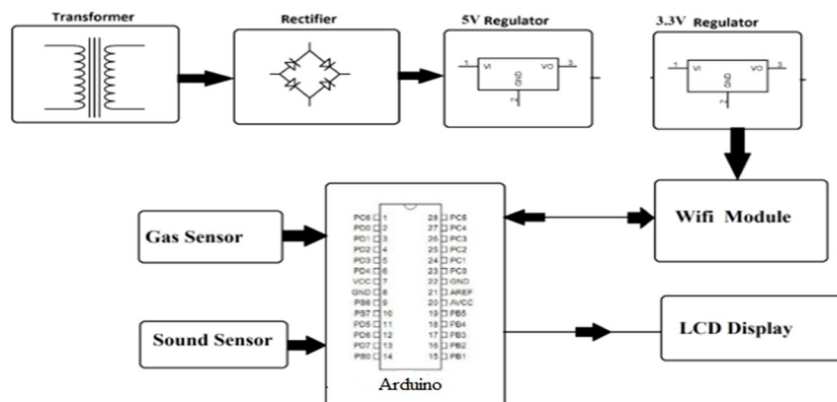

Fig. 2: Block Diagram

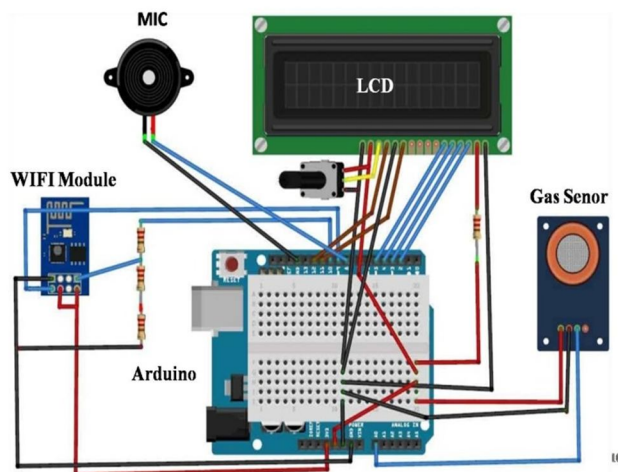

Fig 1: System Architecture

The framework utilizes air sensors to check the nearness of hurtful and dangerous gases/mixes [such as Methane, propane, Butane, alcohol, noxious gases, carbon monoxide etc.] noticeable all around and furthermore utilizes the sound sensor to continue estimating sound dimension in the environment. MQ2 is the air sensors which are utilized to gather air pollution and a sound sensor module mic is utilized to catch sound. These sensors cooperate with Arduino which forms this information and afterward transmit it over the versatile application. To send the information over remote area WI-FI modem is additionally introduced. Furthermore, at whatever point the air pollution is identified, a bell quickly signals and when there is a noise pollution a LED begins squinting constantly. With this framework the specialists as well as the limited individuals can check the transmitted information through their cell phone and that too without spending single penny and the general population can act against it on their dimension and attempt to bring the pollution level under control. This framework would contribute as a section in the working of a sound society.

- 1) *Node MCU Controller:* Node MCU is an open source IOT platform. It includes firmware which runs on the ESP8266Wi-Fi SoC from Espressif Systems, and hardware which is based on the ESP-12 module. The term “NodeMCU” by default refers to the firmware rather than the development kits. The firmware uses the Lua scripting language. It is based on the eLua project, and built on the Espressif Non-OS SDK for ESP8266. It uses many open source projects, such as lua-cjson, and spiffs.
- 2) *Gas Sensor:* Gas sensor detects Pollution.
- 3) *Wi-Fi Module:* A WIFI module is used to communicate with IOT platform
- 4) *LCD Display:* The air pollution is detected, a buzzer immediately beeps and when there is a noise pollution an LED starts blinking continuously.

V. CONCLUSION

In this paper, a successful usage for Internet of Things is utilized for observing air states of condition like air pollution and sound pollution. This paper displays a calculated engineering for an adaptable, adaptable and cost effective for checking the air and sound nature of a specific website. Framework propose an air quality and additionally sound pollution observing framework that enables us to screen and check live air quality and in addition sound pollution in a region through IOT.

REFERENCES

- [1] Dhruvil Shah, Prathmeshn Kudale, Prasad Shirwadkar, Samuel Jacob, IOT Based Air and Sound Pollution Supervising System, IOSR Journal of Engineering, 2018.
- [2] Arushi Singh, Divya Pathak, Prachi Pandit, Shruti Patil, Prof. Priti C. Golar, IOT based Air and Sound Pollution Monitoring System, International Journal of Advanced Research in Electrical, Electronics and Instrumentation Engineering, 2017.
- [3] Sindhu K.G, Shruthi H, Sumanth M.B, Vijayashree H.M, Ayesha A.P, IOT Based Air and Noise Pollution Monitoring System, International Journal of Innovative Research in Science, Engineering and Technology, 2018.
- [4] Ms. Sarika Deshmukh, Mr. Saurabh Surendran, Prof. M.P. Sardey, Air and Sound Pollution Monitoring System using IOT, International Journal on Recent and Innovation Trends in Computing and Communication, 2017.
- [5] P. Sai Chandana, K. Sreelekha, A. Muni Likith Reddy, M. Anil Kumar Reddy, R. Senthamil selvan, IOT Air And Sound Pollution Monitoring System, International Journal on Applications in Engineering and Technology, 2017.
- [6] Anushka Sharma, Vaishnavi Varshney, Roopankb Maheshwari, Upasana Pandey, IOT Based Air And Sound Pollution Monitoring System, International Research Journal of Engineering and Technology, 2018.

- [7] Lalit Mohan Joshi, Research paper on IOT based Air and Sound Pollution Monitoring System, International Journal of Computer Applications, 2017.
- [8] https://www.ijareeie.com/upload/2017/march/49_IOT.pdf [9]http://www.aetsjournal.com/ijaet_issues/Tot-Air-AndSound-Pollution-Monitoring-System-.pdf.
- [10]http://www.ijritcc.org/download/browse/Volume_5_Issues/June_17_Volume_5_Issue_6/1496979869_08-06-2017.pdf.
- [9] Meng-Shiuan Pan and Yu-Chee Tseng, "ZigBee Wireless Sensor Networks and Their Applications" Department of Computer Science National Chiao Tung University Hsin-Chu, 30010, Taiwan, 2007.
- [10] Hemant Ghayvat, Subhas Mukhopadhyay, Xiang Gui and Nagender Suryadevara, "WSN- and IOT-Based Smart Homes and Their Extension to Smart Buildings", Sensors 2015, 15, 10350- 10379; doi:10.3390/s150510350, 2015.
- [11] <https://www.scribd.com/document/363368641/AllAbout-Arduino-Boards>.



Kanchan Wankhade is an assistant prof. at Dhole Patil College of Engineering Pune. Done BE & ME in IT.



Dennis Menezes is a student studying computer science engineering at Dhole Patil College of Engineering Pune.



Zameer Khazi is a student studying computer science engineering at Dhole Patil College of Engineering Pune.



Nachiket Waikos is a student studying computer science engineering at Dhole Patil College of Engineering Pune.



Manish Jha is a student studying computer science engineering at Dhole Patil College of Engineering Pune.



10.22214/IJRASET



45.98



IMPACT FACTOR:
7.129



IMPACT FACTOR:
7.429



INTERNATIONAL JOURNAL FOR RESEARCH

IN APPLIED SCIENCE & ENGINEERING TECHNOLOGY

Call : 08813907089  (24*7 Support on Whatsapp)