



iJRASET

International Journal For Research in
Applied Science and Engineering Technology



INTERNATIONAL JOURNAL FOR RESEARCH

IN APPLIED SCIENCE & ENGINEERING TECHNOLOGY

Volume: 7 Issue: 1 Month of publication: January 2019

DOI: <http://doi.org/10.22214/ijraset.2019.1142>

www.ijraset.com

Call:  08813907089

E-mail ID: ijraset@gmail.com

Off-Grid Solar Power Bank

M. Karthikeyan¹, C. Arul Kumar², A. Rathinam³

^{1, 2, 3}Department of EEE & Paavai Engineering College, Namakkal, Tamil Nadu-6370 018, India.

Abstract: In this paper, a single-switch two-stage DC-DC conversion circuit is proposed for an off-grid solar power application. A photovoltaic (PV) panel powers the load and a storage unit (battery) via the proposed circuit. The battery is designed to balance the supply and the demand of power under different irradiation situations. Based on conventional cascaded DC-DC converters, the proposed design is developed with the single switch technique reducing size, cost and power loss. The control scheme in this design is pulse width modulation (PWM) with pulse frequency modulation (PFM). The PWM module is similar to conventional design except its ramp signal with a variable frequency is provided by a resettable integrator. As a result, the PWM and PFM modules regulate the two stages of the proposed circuit separately with the same switching control signal. In this paper, the modes of operation of the circuit are discussed as well as the control schemes. The design process is described along with the circuit analysis and comparisons with conventional design are made as well. A prototype has been built to verify the proposed circuit with simulation and experimental results.

Keywords: Single-switch technique, photovoltaic power system, off-grid solar system, DC-DC conversion, resettable integrator, pulse frequency modulation (PFM), pulse width modulation (PWM).

I. INTRODUCTION

Renewable energy provides greater options addressing society concerns about the depletion of the fossil fuel. One source of renewable energy, solar energy, is converted from sunlight using Photovoltaic (PV) panels. The solar panels are widely installed for civil use. The power supplied by the solar panels is usually DC and not stable at all times. Therefore DC-DC or DC-AC conversion is required before the solar panels supply the load or are connected to the power grid. Energy storage is also needed to absorb the excess power from the source and supply the load during irradiation times. The three-port topologies for the renewable energy have been designed and investigated widely by power engineers and researchers. A great number of topologies have been developed for cascaded converters as well as converters working in parallel. These converters are built for different circumstances, such as on grid or off-grid applications.

The conventional designs normally regulate the converters separately and require a certain number of components, such as at least one switch in each converter. Some studies attempt to combine the components of different converters to improve the circuitry as well as their size and performance. In particular, the switch can be shared by the converters with the single switching technique. Based on this technique, a design of single switch cascaded converters is developed for an off-grid PV power system. Since the switch has to control two different converters, the Pulse Frequency circuit along with the pulse width modulation (PWM) as the traditional design.

The proposed PFM module is developed with a resettable integrator which generates ramp signal with variable frequency. Then the switch control for two converters is achieved simultaneously. The advantages of the proposed circuit include reducing the number of the components as well as the power loss in the power conversion.

This paper consists of the following parts: section 2 introduces the main circuit of the proposed two-stage conversion circuit along with its regulation schemes, its operation modes and the battery modes. Section 3 describes the design process of this study as well as the circuit specifications. The comparison between the proposed design with the conventional is discussed regarding the maximum ratings in this section.

For the off-grid solar application, a two-stage conversion is applied to deliver power from the input to the load as well as the energy storage unit. A boost converter is series connected to a buck converter in the conventional design Fig.1(a). It supplies the load when there is insufficient or even no input power. The inductors L_1 and L_2 maintain the continuous inductor currents while the capacitors C_1 and C_2 stabilized the battery voltage and the output voltage respectively. In other words, the two duty ratios D_1 and D_2 are related to the voltages of their own stages only and different from each other. The same switching frequency f is applied to both switches unless there is another requirement.

II. LITERATURE REVIEW

Conventional energy conversion architectures in photovoltaic (PV) systems are often forced to tradeoff conversion efficiency and power production. This paper [1] introduces an energy conversion approach that enables each PV element to operate at its maximum power point (MPP) while processing only a small fraction of the total power produced. This is accomplished by providing only the mismatch in the MPP current of a set of series-connected PV elements. In the [2] paper we show performances of improved DC-DC converters able to feed an inverter. Resulting efficiency allow us to consider parallel HVDC architecture connecting independently PV modules with low section wiring. The design [3] for stable operation of such systems requires consideration of the stability conditions for all possible structures and operating modes. A stand-alone photovoltaic-battery hybrid power system is studied for illustrating the possible complex behavior in this paper. We reveal smooth bifurcation, including slow-scale Neimark-Sacker bifurcation, fast-scale period-doubling bifurcation as well as coexisting bifurcation. Under certain conditions, when the system switches its operating mode, a non smooth bifurcation, manifested as a jump between stable and unstable behavior, can also be observed. A new [4] research trend in the residential generation system is to employ the PV parallel-connected configuration rather than the series-connected configuration to satisfy the safety requirements and to make full use of the PV generated power. How to achieve high-step-up, low-cost, and high-efficiency dc/dc conversion is the major consideration due to the low PV output voltage with the parallel-connected structure. The limitations of the conventional boost converters in these applications are analyzed. Then, most of the topologies with high-step-up, low-cost, and high-efficiency performance are covered and classified into several categories.

The paper [5] intends to develop a Parameter Optimization (PO) algorithm for designing and developing of LLC-RC. The proposed algorithm overwhelms the limitation by introducing a non conceptual model based on the simulated outcome. Specifically, the resonant current under start-up conditions is acquired from the literary outcome, and the intelligent model is constructed. Based on the proposed model, a renowned search algorithm called as Whale Optimization Algorithm (WOA) is exploited to optimize the time constant of the resonant converter, which is a critical design parameter. A photovoltaic(PV) panel powers the load and a storage unit(battery) via the proposed circuit [6] . The battery is designed to balance the supply and the demand of power under different irradiation situations. Based on conventional cascaded DC-DC converters, the proposed design is developed with the single switch technique reducing size, cost and power loss. The control scheme in this design is pulse width modulation(PWM) with pulse frequency modulation(PFM). A high-efficiency pulse-frequency modulation (PFM) boost DC-DC converter with adaptive on-time (AOT) control method is proposed [7]. A novel three-step startup procedure is proposed and applied on the boost converter, which makes the converter start up with a below-threshold voltage. Besides, adaptive on-time control method can reduce the output ripple dramatically.

A. Control Schemes

Based on the requirements of the proposed application, the control circuit should be able to regulate the voltage of the PV unit according to a reference given by the circuit designer or the maximal power point tracking (MPPT). At the same time, it sustains a constant load voltage. For conventional converters, two simple PWM controllers generate two pulse signals with different duty ratios D_1 and D_2 for the two switches S_1 and S_2 regulating the PV voltage and the load voltage respectively. The switching frequency f is not specified since it is not relevant to the voltage relationships.

For the proposed design, only one control signal is available for the single switch. In this case, the operational modes of the converters are modified to suit the same switching method in the different stages. To achieve this, the converter in the first stage works under the discontinuous conduction modulation (DCM) with a discontinuous inductor current. Meanwhile, the operation of the battery-load conversion is discontinuous.

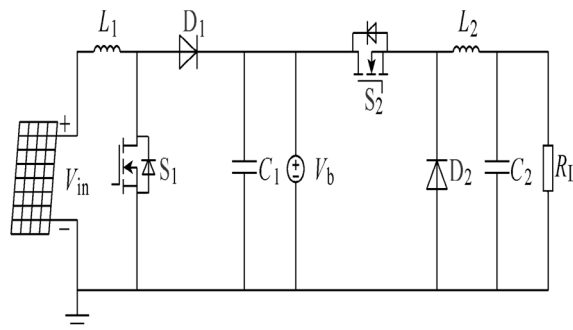

(a) The proposed design

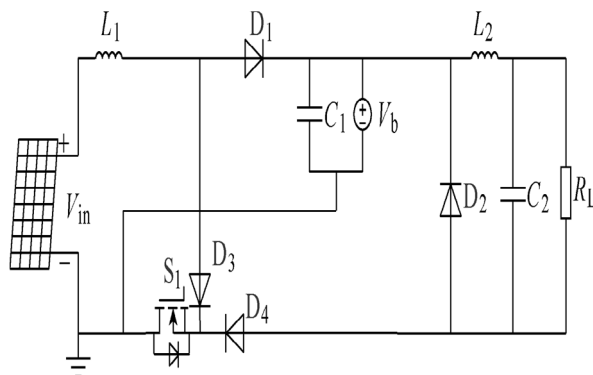

Fig.1 Diagram of cascaded DC-DC converters for the proposed application

Conduction modulation (CCM), the same as the conventional operation. As a result, the control variables of the system become the duty ratio D and the switching frequency f . The load voltage is determined by D only due to CCM. In the first stage, the voltage conversion is related to both the duty ratio D and the switching frequency f as a result of DCM. However, the duty ratio D is governed by the CCM controller and is relatively constant. Thus the frequency f can be treated as the only control variable for the first stage.

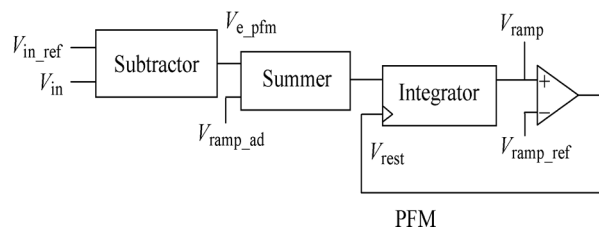

Fig 2 (a) PWM control

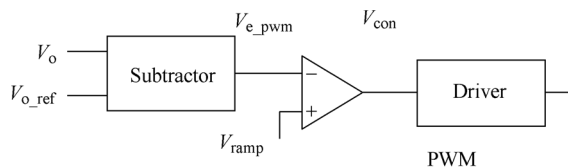

Fig 2 (b) PFM control

The control scheme of the PWM controller is similar to the conventional one for CCM operation, as shown in Fig.2(a). The controller compares the load voltage V_o with the reference V_{o_ref} and generates an error V_{e_pwm} . In the proposed design, this error signal V_{e_pwm} is not compared with a constant ramp signal provided by an oscillator as with the traditional PWM controller. Instead, the ramp waveform is given by the PFM controller. The comparator generates a pulse wave V_{con} determined by the relation of the error and the ramp for the driver to drive the single switch. The PFM controller provides a saw tooth wave with a relatively fixed magnitude and variable frequency f determined by the PV voltage error V_{e_pfm} as displayed in Fig.2(b). In the PFM controller, the voltage of the solar panel V_{in} is examined based on the reference V_{in_ref} . The error V_{e_pfm} forms the input of a resettable integrator. Since the V_{in} is relatively constant in one period of switching, the input of the integrator is assumed to be constant. Once the integral is greater than a certain value V_{ramp_ref} , the capacitor of the integrator is shorted and the integrator is reset. With different values of the error V_{e_pfm} , the slope of the ramp is changed so that the width of the ramp is controlled as well as the frequency. In the PFM controller, the V_{ramp_ad} is designed to adjust the input of the integrator. Moreover, PI units are utilized in the proposed design as well as inverters. The control modules are designed with the op-amps for the prototype. Regulation chips with adjustable oscillators can be used to simplify the control modules.

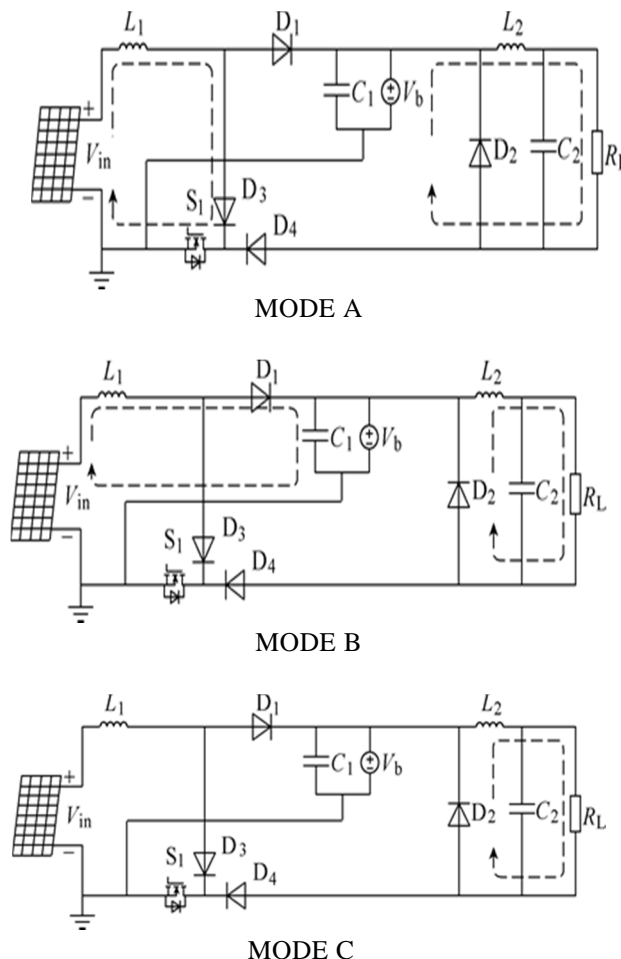
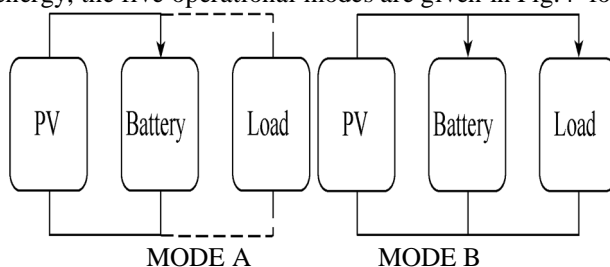

Fig.3 Operational mode of the proposed circuit.

- 1) *Mode 2:* After the on-period, the MOSFET S_1 is turned off by the control signal and the proposed circuit operates in mode 2. Both of the inductors start releasing their energy. The current paths are shown in the Fig.3(b). The inductor current i_{L1} flows through the diode D_1 to supply the battery in the first stage. Similarly, the load loses the power supply from the battery due to the open switch. The current path consists of the inductor L_2 , the load and the diode D_2 .
- 2) *Mode 3:* Once the inductor L_1 is discharged completely, the proposed circuit starts running in this mode. The single switch remains de-energized as in the previous mode. There is no current ($i_{L1} = 0$) flowing in the first stage due to DCM. In contrast, the current i_{L2} has the same discharge slope given by (4) because of CCM.

B. Operational Modes Of The Battery

The energy store unit in the proposed converters is designed to provide a stable voltage to the load in different situations. Since the power given by the PV panel does not always match the demand of the load due to some influences like shading, the battery stores the excess power from the input or works as a complementary power supply. Assuming the SOC of the battery is in a range that it can absorb and supply energy; the five operational modes are given in Fig.4 for the battery.



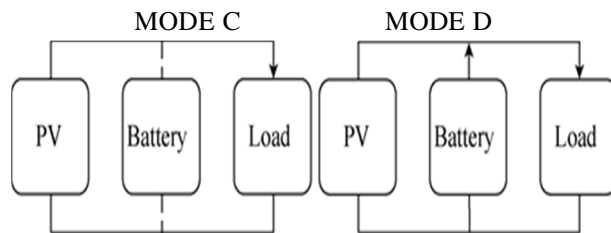
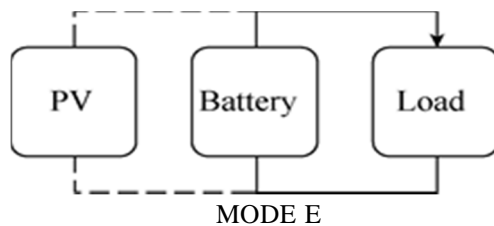

Fig.4 Five modes of the battery operation in the proposed design

- 1) *Mode A*: If the PV panel supplies power normally but the device in the load is turned off, the battery will absorb all the power from the input. The average charged current is positive for battery. The proposed circuit operates with its first stage as a conventional converter. Switches can be added to disconnect the load or the second stage based on the requirement.
- 2) *Mode B*: When the supply power from the solar unit is greater than the load demand, the battery is charged with the excess. This mode happens when the load device operates with a light load.
- 3) *Mode C*: This is a situation that power supply is equal to the load demand. In this case, the battery does not absorb or supply any power. Therefore, the average of the charging current is zero.
- 4) *Mode D*: When the supply power is insufficient to meet the load demand due to shading or low irradiation, the battery supplies the load as a complementary power source. The battery is discharged and the average current of charging is negative in this mode.



- 5) *Mode E*: When there is no power provided by the PV panel, the battery will supply the load fully. This mode usually happens during the night with the insufficient irradiation. In this mode, the first stage of the proposed circuit is disabled while the second stage works as a conventional converter to supply the load. Although the diode D_1 will prevent reverse current from the battery theoretically, a protection diode can be installed for the solar unit if necessary.

III. SIMULATION AND EXPERIMENTS

The prototype of the proposed circuit is built according to the design

A. Comparison of the key components

The main circuit of the proposed prototype is compared with the conventional design of the cascade converters. Regarding the component difference between the two designs, the proposed design has one switch less than the conventional while two more diodes are necessary to regulate the current for the single switch. The prices of these key components are summarized in Table II. The price data is provide don the website of a distributor of technology products in Australia dollars. The prices are for prototype-making on a small scale only. However, these can reflect the advantage of the proposed design to some extent regarding the cost. But in general; the proposed circuit reduces the cost of the key components by about 47%.

Moreover, the dimension of the circuit is decreased dramatically due to omitting one heat sink for the switch. The heat sink used for the switches is one of the largest components with the size

B. Comparison Of The Switching Loss

One of the main power losses in the voltage conversion is the power loss in the switching. By sharing the current path, the proposed circuit is able to reduce the switching loss to some extent. With the same specification above except the fixed resistance R_L , the power loss during the on-period of the MOSFETs is compared with different input powers, $P=2W$ and $P=5W$. It is assumed that the battery is in mode C which does not affect the power conversion in both stages of the proposed circuit. In both cases, V_o and V_b are fixed while V_{in} is changing for 1V to 5V. The duty ratio of the proposed design is 0.2 while the duty

ratios of the conventional design are determined by the input and output voltages. IRFB4110PBF MOSFET with average low static drain-to-source on-resistance ($R_{DS} = 3.7\text{m}\Omega$) is used for all controlled switches in both designs. The proposed design reduces the switching loss when they are energized by up to 50%. A certain amount of loss improvement can be found in the normal operational range of V_{in} . When V_{in} is close to V_b , the performance of the proposed circuit is close to the conventional regarding the on-period switching loss.

C. Experimental Results

The prototype tested in this study has the same specification as the previous simulation. It connects the PV power source with the storage unit and the load as the circuit diagrams in the previous analysis. Similar to the simulation model, the prototype ensures the steady output voltage as well as the input. The waveforms of the inductor currents observed from an oscilloscope confirm the DCM operation of the inductor L_1 along with the CCM mode of the inductor L_2 , as shown in Fig.10(a). Moreover, the battery works like the analysis because the waveform of its current i_b is the same as the simulation result. The experimental results verify the correct operation of the proposed design.

IV. CONCLUSION

A design of two-stage DC-DC converters with a single switch is introduced in this paper for off-grid solar power applications. The main switches of the conventional design are substituted by one single switch with some auxiliary diodes. The proposed design is described with its main circuit as well as its control schemes. With the help of PFM+PWM modulation, the proposed circuit is able to function as the conventional design with the single switch.

Furthermore, the size, the cost and the power loss are improved by the new design in this paper as shown in fig 6. The design process is provided with the analysis of the proposed circuit. The waveforms of the simulation and experimental results validate the function of the proposed circuit. The proposed study has a broad range of perspectives and can be investigated further for several issues. The application in other renewable power systems could be studied as well as on-grid power systems. Moreover, the auxiliary and protection circuits can be developed for low irradiation situation and the extreme cases of the battery (exhausted or full-charge SOC). The rearrangement of the regulation schemes can be discussed in the future as well.

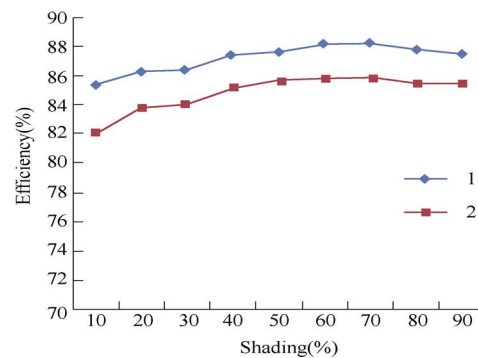

Fig.6 The efficiency comparison of different shading conditions: η_1 : The proposed design; η_2 : The conventional design.

REFERENCES

- [1] P. S. Shenoy, K. A. Kim, B. B. Johnson, and P. T. Krein, "Differential power processing for increased energy production and reliability of photovoltaic systems," IEEE Transactions on Power Electronics, vol. 28, no. 6, pp. 2968-2979, 2013.
- [2] G. R. Walker, and P. C. Sernia, "Cascaded DC-DC converter connection of photovoltaic modules," IEEE Transactions on Power Electronics, vol. 19, no. 4, pp. 1130-1139, 2004.
- [3] X. Xiong, C. K. Tse, and X. Ruan, "Bifurcation analysis and experimental study of a multi-operating-mode photovoltaic- battery hybrid power system," IEEE Journal on Emerging and Selected Topics in Circuits and Systems, vol. 5, no. 3, pp. 316-325, 2015.
- [4] W. Li, and X. He, "Review of nonisolated high-step-up DC/DC converters in photovoltaic grid-connected applications," IEEE Transactions on Industrial Electronics, vol. 58, no. 4, pp. 1239-1250, 2011.
- [5] H. Wang, Y. Chen, Y. F. Liu, J. Afsharian, and Z. Yang, "A passive current sharing method with common inductor multiphase LLC resonant converter," IEEE Transactions on Power Electronics, vol. 32, no. 32, pp. 6994-7010, 2017.
- [6] L. An, and D. D. C. Lu, "Design of a single-switch DC/DC converter for a PV-battery-powered pump system with PFM+PWM control," IEEE Transactions on Industrial Electronics, vol. 62, no. 2, pp. 910-921, 2015.
- [7] H. H. Wu, C. L. Wei, Y. C. Hsu, and R. B. Darling, "Adaptive peak-inductor-current-controlled PFM boost converter with a near-threshold startup voltage and high efficiency," IEEE Transactions on Power Electronics, vol. 30, no. 4, pp. 1956-1965, 2015.



10.22214/IJRASET



45.98



IMPACT FACTOR:
7.129



IMPACT FACTOR:
7.429



INTERNATIONAL JOURNAL FOR RESEARCH

IN APPLIED SCIENCE & ENGINEERING TECHNOLOGY

Call : 08813907089  (24*7 Support on Whatsapp)