



iJRASET

International Journal For Research in
Applied Science and Engineering Technology



INTERNATIONAL JOURNAL FOR RESEARCH

IN APPLIED SCIENCE & ENGINEERING TECHNOLOGY

Volume: 7 Issue: III Month of publication: March 2019

DOI: <http://doi.org/10.22214/ijraset.2019.3042>

www.ijraset.com

Call:  08813907089

E-mail ID: ijraset@gmail.com

E Health Glove using IoT

Ms. Ramya Devi¹, Sri Bargavi V², Yuvarani V³

^{1,3}Department of Computer Science and Engineering, S.A. Engineering College, India

Abstract: Today, the implementation of new health services for the elderly has become a serious need. There have been distinct health challenges in society through health-related technical innovation. Most elderly people today experience loneliness and psychological depression either because they live alone or because of reduced relationships with their families. We have proposed an IoT (Internet of Things) based healthcare system to integrate various technologies of wearable devices, sensors and wireless sensor networks to provide intensive service to improve the quality of services in the elderly healthcare system. This method would support the real-time activity and monitor elderly citizens' health status. The information collected by various wearable devices in real time will be stored in the purpose-based system in the central database, which connects people, doctors and ambulances in an emergency to obtain the right information. This means that the system can improve accessibility, efficiency and also reduce health costs in order to improve the comfort, safety and management of daily routines for the elderly.

Keywords: wearable device, intensive service, central database, Internet of Things, innovation.

I. INTRODUCTION

In addition to the developments in hospital equipment and pharmaceuticals, new catalysts for technological innovations such as the Internet have become a viable platform for the elderly. Connectivity and communication gaps are superfluously bridged through these creative applications. The IoT (Internet of Things) is a technology of the next generation that connects unique smart objects and sensors based on the Internet's backbone. They are connected in an advanced way and can go beyond the interactions between machine and machine. The elderly healthcare system can be advanced with this automation Global health services are facing challenges due to the rapid growth of the elderly population, so a creative way is needed to meet this challenge due to the recent development of electronics and many devices have been developed that can monitor the health record of patients in real time and can be monitored remotely via the Internet. The IoT enabled monitoring devices have RFID (Radio Frequency Identification) associated with it. The aim of the project is to continually monitor the heart beats and temperature of the user who has the heart beat sensor and temperature sensor in place. If the heartbeat or temperature exceeds or eludes the specific limit, the system sends a message to the family member and doctor in the database of users.

II. LITERATURE SURVEY

Heart beats are very important for the health of human or we say patient. The quality of the service is enhanced by using IOT. Increases the accessibility, efficiency and improves safety and comfort. It is used to provide early treatment and detect the danger signs. It is cost efficient and provides high security. Using RFID these devices can be accessed over the internet at any time. The length of hospital stay is minimized and the physicians can monitor patients online. The wearable medical devices is used to improve the quality of diagnosis and treatment for range of medical conditions. The wearable device comes with extreme sizes and power constraints and security solution such as cryptography. This is based on medical security monitor that snoops all communication to/from medical devices. It is an effective method for enhancing the security of existing medical devices they are already deployed or upcoming products cannot be easily modified.

III. IMPLEMENTATION

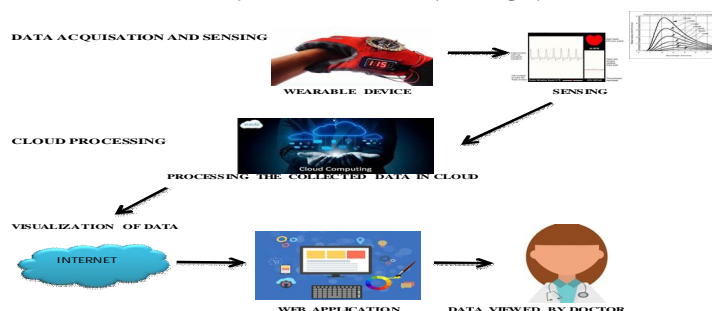

Fig. 1 Architecture Diagram

A. Architecture

Initially the data about the heart beat and temperature is collected from the wearable device (glove). Once the both sensors sense the data it is captured by the cloud environment and it is stored there. Using internet the data can be viewed in web page by logging into the particular user id by providing the password. The data about the patient can be viewed only by the particular doctor and the patient’s relatives. This device is designed for post operated patients staying in home with continuous monitoring.

B. Data Flow Diagram

The block diagram explains how the data is sensed by the heart beat and LM 35 temperature sensor and then the data is stored in cloud server through Arduino controller and the GPS is used to track the location of the patient. Finally all the readings can be viewed through web application.

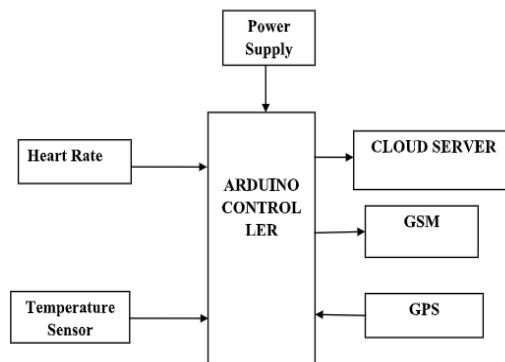

Fig. 2 Flow diagram

C. Working

In this project we are using Arduino micro controller to develop IoT based application. For elderly persons, Help to You (H2U) is developed that measures heart beats and blood pressure of the person is measured continuously. Pressure sensor measures the pressure and Systolic and diastolic pressure is calculated. The heart beats are measured by Heart beat sensor. If heart beats or Blood pressure become abnormal, SMS is sent to doctors or family members along with current location of that person. Location is tracked by using GPS modem. Buzzer also sounds at that time. The parameters of the person are displayed on the webpage that can be accessed from anywhere.



Fig. 3 Glove

D. Heart beat sensor

Heart beats are very important for the health of human or we can say patient. Heartbeat sensor works on a principle that blood in the human body pumps with every heartbeat. We have used a LDR and Red LED. Patient needs to place her/his finger between these two components. Red light will reflect from patient’s finger to LDR. And blood will pump with every heartbeat. This causes fluctuations in the light intensity. Heart beat sensor used in this system works on the above principle. It gives high pulses with every heartbeat. It works on pure 5 volt DC.

E. Temperature sensor

Temperature is the body's degree of heat, which is a measure of the body's heat content. The problem of quantifying the body's heat content on a scale did not arise until the steam engine was invented. One of the first references to 'temperature' dates back to 1760, when Joseph Black stated that different temperatures resulted from the same heat applied to different materials. Years of rigorous scientific study have led to many theories ranging from the simple concept of 'caloric,' which treated heat as a material substance exchanged between materials, to Carnot's description of heat as a form of energy.

IV. ADVANTAGES

- A. Utilizing a heart rate monitor for any activity gives you definitive data on what effort level it takes you as an individual to accomplish a given task as well as under what circumstances.
- B. A heart rate monitor is a fantastic tool giving you clear indication and evaluation of the condition of your cardiovascular system during physical activity.
- C. Using heart rate monitor can be your personal coach. Your heart rate along with your "perceived exertion rate" can tell you if you need to up your intensity, pull back and or tell you that you are in your groove.
- D. Indicates your heart's ability to "recover" from a given exercise and or interval within a workout once again giving you more info on the condition of your cardiovascular system. Faster recovery rate indicates enhanced cardiovascular capacity.

V. CONCLUSION

IoT health care system predictive analytics can provide early treatment and detect signs of danger early in order to prevent hospitalization. The length of hospital stay is minimized and patients can be connected and monitored by the doctor and nurses based on the report generated by the patient's real-time sensors and clinical updates on the database server. It will also help the patient to intervene from any concerns that will hopefully prevent problems when they stay alone at home. Interaction via the IoT system is quite cost-effective and guarantees a higher level of communication security.

VI. FUTURE WORK

The Future work of the project is very essential in order to make the design system more advanced. In the designed system the enhancement would be connecting more sensors to internet which measures various other health parameters and would be beneficial for patient monitoring i.e. connecting all the objects to internet for quick and easy access. Establishing a Wi-Fi mesh type network to increase in the communication range.

REFERENCES

- [1] Mohammad Pourhomayoun, Nabil Alshurafa, Foad Dabiri, Ehsan Ardestani, Ahsan Samiee, Hassan Ghasemzadeh, Majid Sarrafzadeh, "Why Do We Need a Remote Human-Health Monitoring System? A Study on Predictive Analytics for Heart Failure Patients", JOMS, June 2011a
- [2] Ananda Mohon Ghosh, Debashish Halder, SK Alamgir Hossain, "Remote Human-Health monitoring System through IoT", 2016 5th International Conference on Informatics, Electronics and Vision (ICIEV).
- [3] Mohammad Wajih Alam1, Tanin Sultana2 and Mohammad Sami Alam3," A Heartbeat and Temperature Measuring System for Remote Human-Health monitoring using Wireless Body Area Network", International Journal of Bio-Science and BioTechnology Vol.8, No.1 (2016), pp.171-190.
- [4] S.M.R. Islam, D. Kwak, MD.H Kabir, M. Hossain and K.-S Kwaki, "The Internet of things for health care: a comprehensive survey," IEEE Acces, vol. 3, pp.678-708, Jun. 2015.
- [5] M. Kumar, "Security issues and privacy concerns in the implementation of wireless body area network," in Proc. of Int. Conf. on Information Technology, Bhubaneswar, Odisha, India, pp.58-62, Dec. 2014.



10.22214/IJRASET



45.98



IMPACT FACTOR:
7.129



IMPACT FACTOR:
7.429



INTERNATIONAL JOURNAL FOR RESEARCH

IN APPLIED SCIENCE & ENGINEERING TECHNOLOGY

Call : 08813907089  (24*7 Support on Whatsapp)