



iJRASET

International Journal For Research in
Applied Science and Engineering Technology



INTERNATIONAL JOURNAL FOR RESEARCH

IN APPLIED SCIENCE & ENGINEERING TECHNOLOGY

Volume: 7 Issue: III Month of publication: March 2019

DOI: <http://doi.org/10.22214/ijraset.2019.3227>

www.ijraset.com

Call:  08813907089

E-mail ID: ijraset@gmail.com

Smart Air Pollution Detection System using Arduino

Ritesh Kumbhare¹, Prarthana Ghadle², Mahendra R Zode³, Prof. Saurabh Nimkar⁴

^{1, 2, 3}Scholar of Electronics and Telecommunications, JDCOEM, Nagpur, India

⁴Assistant Professor, Electronics and Telecommunications, JDCOEM, Nagpur, India.

Abstract: The pollution is a major problem for human health. Therefore, we consider that and decide to make the smart air pollution monitoring and detecting system. In that system, different gas sensors are included i.e. air quality sensor, carbon monoxide sensor, LPG, ethanol, etc. These sensors sense different gasses present in the air and the quantity of that gasses shows on the monitor in PPM (Parts Per Million). This process makes easy by using Arduino device. And also this device based on IOT (Internet of Thing).

Keywords: Arduino Uno board, Carbon dioxide sensor, Wi-Fi module, Buzzer.

I. INTRODUCTION

We studied present gases in the atmosphere. So we have observed that according to NASA for pure air:

- 1) Nitrogen-78%
- 2) Oxygen-21%
- 3) Argon-0.93%
- 4) CO₂-0.04%
- 5) Minimum amounts of neon, helium, methane, krypton and hydrogen as well as water vapor.

And when studied the hazardous gas in the atmosphere, we have to observe the CO₂ is the toxic gas when it's level going above the safe level. In current, the CO₂ level increases in the air that can be dangerous for human life. The CO₂ gas invites to the pollution. The major problem of the every nation is "Air Pollution". It is growing the health problems and other problems. Main reason of the CO₂ increased are growing number of vehicles and industrialization.

So we check the safe level of CO₂ gas in the atmosphere which is 350 to 400 PPM . According this level we decide to make the Smart air pollution detection system.

We have observed that different readings of the Indian cities. These are following:

GAS	CO ₂ level (ppm)	NAGPUR	MADH YPRAD ESH	DEHLI
CO ₂	350-400	415-420	405-410	400-405

A. Project Overview

In our project Air Pollution Detection System, we have to consider the hazardous gas CO₂ that's affects on the atmosphere. Choose CO₂ sensor for the detecting the CO₂ gas, the sensor senses the physical quantity, the signal convert into the electrical signal and gives the value in PPM(Parts Per Million). Arduino Uno board used for the controlling purpose and also provide the power to these devices, it controls the other devices connected in the system i.e. LCD display, sensor, Wi-Fi module, buzzer, LEDs. LCD display shows the output data of the sensor through the Arduino board.

B. Requirements

1) Hardware Components

- a) Arduino Uno
- b) ESP8266 WIFI Module
- c) CO2 Sensor (MQ - 7) 16*2 LCD Display
- d) Buzzer
- e) LED
- f) 1K ohm Resistor
- g) 220 ohm Resistor

2) Software

Arduino IDE (Arduino 1.8.8)

Thingspeak Server

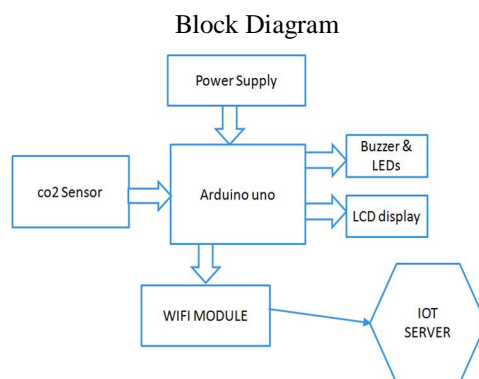

Fig. 1 Block Diagram of System

C. Working

The Smart Air pollution detection system consists of the Arduino Uno which is based on ATmega328 microcontroller. The system is controlled by the Arduino. Initially, the Arduino is provided with a 5 V DC supply through port 9600 to the sensor and LCD display. Now the CO2 gas sensor is connected to the analog pin (A0). The sensor provides the data to the Arduino board that is displayed on the LCD display continuously, LCD Display is connected to 2,3,4,5,12,13 pins in the arduino board and if the Co2 gas exceeds the set limit of safe level then the output is shown in the analog form on the LCD display and Red Led (connected to the 9th pin) will ON and the buzzer (connected to the 8th pin) simultaneously buzz. Now the data which is retrieved from gas sensor will be provided to the wi-fi module which is connected to the 3.3 V pin on the Arduino board. This wi-fi module (ESP -01 module) will then provide this data to the Thingspeak server ,this process create the IOT platform.

D. Experimental Setup

We have installed our device at place Fetri, Nagpur from 11am to 3pm on date 14/03/2019 so as per the observation the following readings are as follows:

DATE	TIME	CO2 Level (ppm)
14/03/2019	11am-12pm	399
	12pm-1pm	400
	1pm-2pm	368-375
	2pm-3pm	405

E. Components

- 1) **Arduino Uno:** Arduino Uno board having a microcontroller the ATmega328P. And it is an open source microcontroller board. It has 14 digital input/output pins 6 analog inputs, a 16 MHz quartz crystal, a USB Connection, power jack, an ICSP header and a reset button. The board is equipped with sets of digital and analog input/output(I/O) pins that may be interface to expansion boards and other circuits. The boards feature serial communication interfaces, including universal serial Bus (USB) on some models, which are also used for loading from personal computers. The arduino project provides an Integrated Development Environment (IDE) based on the processing language project. The sensor having a high sensitivity and fast response time. The sensor's output is an analog resistance. The drive circuit is very simple all you need to do is power the heater coil with 5V adds a load resistance and connects the output to an Arduino's analog pin.



Fig. 2 Arduino Uno Board

- 2) **ESP8266 Wi-Fi Module:** The ESP8266(ESP-01) is a low-cost Wi-Fi chip having full TCP/IP stack and microcontroller unit (MCU) capability. Wi-Fi module runs on 3.3V and gives our system access to Wi-Fi or internet. ESP8266 is Wi-Fi enabled system on chip (SoC) module development by Espressif system. It is mostly used for development of IoT (Internet of things)

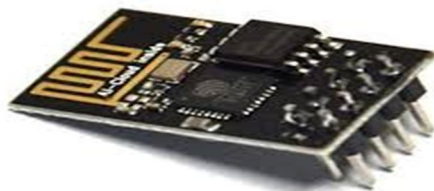

Fig. 3 ESP8266 Wi-Fi Module

- 3) **CO₂ Sensor (MQ - 7):** Carbon Dioxide (CO₂) sensor suitable for sensing CO₂ concentrations in the air. The MQ-7 can detect CO₂-gas concentrations anywhere from 20 to 2000ppm. They are used in gas detecting equipment for carbon. The sensor having a high sensitivity and fast response time. The sensor output is an analog resistance. The drive circuit is very simple all you need to do is power the heater coil with 5V adds a load resistance and connects the output to an Arduino's analog pin. The Enveloped MQ7 gas sensor have 6 pins, 4 of them are used to fetch signals, and other 2 are used for providing heating current. The MQ7 gas sensor is composed of the micro AL₂O₃ ceramic tube. Tin Dioxide (SnO₂) sensitive layer, measuring electrode and heater are fixed into a crust mode of plastic and stainless steel net. The heater provides necessary work conditions for work of sensitive component.



Fig. 4 CO₂ Sensor

- 4) *16*2 LCD Display*: The LCD Display is a basic (16x2) 16 character by 2 line display. It is used to indicate the gas present in the atmosphere in PPM. The sensor's output is an analog resistance. The drive circuit is very simple all you need to do is power the heater coil with 5V adds a load resistance and connects the output to an Arduino's analog pin.



Fig. 5 16*2 LCD Display

- 5) *Buzzer*: Buzzer is a tiny speaker, you can connect direct with the Arduino. Connect one pin to the Arduino's ground and other pin to digital pin of Arduino.



Fig. 6 Buzzer

F. Applications

- 1) Use in industry, for check the level of CO₂
- 2) It is used to detect the CO₂ for controlling air pollution.
- 3) Place in squares, to prevent the air pollution because CO₂ is the hazardous gas.

REFERENCES

- [1] Harsh Shah, Zishan Khan, "IOT based Air Pollution Monitoring System ", Publishhed in IJSER, vol. 9, Issue 2, Feb 2018.
- [2] Poonam Pal, Ritika Gupta, "IOT based Air Pollution Monitoring System Using Arduino", Publishhed in IRJET, vol. 4, Issue 10, Oct 2017.
- [3] Ch. V. Saikumar ,M. Reji , P. C. Kishoreraja, "IOT Based Air Quality Monitoring System", Published in IJPAM, volume 117, No. 9, 2017
- [4] Navreetinder Kaur, Rita Mahajan, Deepak Bagai, "Air Quality Monitoring System Based on Arduino Microcontroller", Published in IJRASET, volume 5, Issue 6, June 2016.



10.22214/IJRASET



45.98



IMPACT FACTOR:
7.129



IMPACT FACTOR:
7.429



INTERNATIONAL JOURNAL FOR RESEARCH

IN APPLIED SCIENCE & ENGINEERING TECHNOLOGY

Call : 08813907089  (24*7 Support on Whatsapp)