



iJRASET

International Journal For Research in
Applied Science and Engineering Technology



INTERNATIONAL JOURNAL FOR RESEARCH

IN APPLIED SCIENCE & ENGINEERING TECHNOLOGY

Volume: 7 Issue: III Month of publication: March 2019

DOI: <http://doi.org/10.22214/ijraset.2019.3234>

www.ijraset.com

Call:  08813907089

E-mail ID: ijraset@gmail.com

A Review on Application Areas of Wireless Power Transfer

Ajay Nagar¹, Ajay Meena², Dr. Deepika Chauhan³

^{1, 2, 3}Electrical Engineering, Poornima College of Engineering, Jaipur

Abstract: *The wireless power transfer technology changes our lifestyles. The wireless power transfer technology so far has widely been implemented via magnetic induction that features direct contact with devices. The wireless power transfer technology also uses magnetic resonance technology, a more advanced alternative that provides power transfer within a certain distance range without requiring direct contact with devices. This paper carries out a pilot study to present the different application areas of wireless power transfer technology along with the basic concept of this technology.*

Keywords: *Wireless Power Transfer (WPT), Transportation, Medical, Railways, Home Appliances, Military, Resonant Coupling.*

I. INTRODUCTION

Battery charging of wireless power transfer is a novel methodology. However, the idea of wireless power transfer notwithstanding to charge batteries is certainly not another thought. It has been concocted by analysts but not generally executed yet. Wireless power transfer is altering the method of power transmission to empower the dependable and effective wireless charging of many regular electronic gadgets with coordinating a power source to an electrical burden without the guide of wires. Such a transmission is utilized in situations where interconnecting wires are perilous or awkward [1].

Right now, engineers are endeavoring to find how to expand the effectiveness of intensity transmitted wirelessly and furthermore strategies that are safe to individuals and the earth, techniques that are less expensive and subsequently can be financially feasible. Though still in the beginning periods, a few electronic organizations are starting to take off gadgets that can wirelessly transmit control.

Wireless power transmission (WPT) depends on the principle of electromagnetic prompting. Electromagnetic induction takes a shot at the idea of an essential loop producing a transcendentally attractive field and an auxiliary curl being inside that field so a current is prompted inside its curls. This causes a generally short range because of the measure of intensity required to deliver an electromagnetic field [2].

II. BASIC CONCEPT

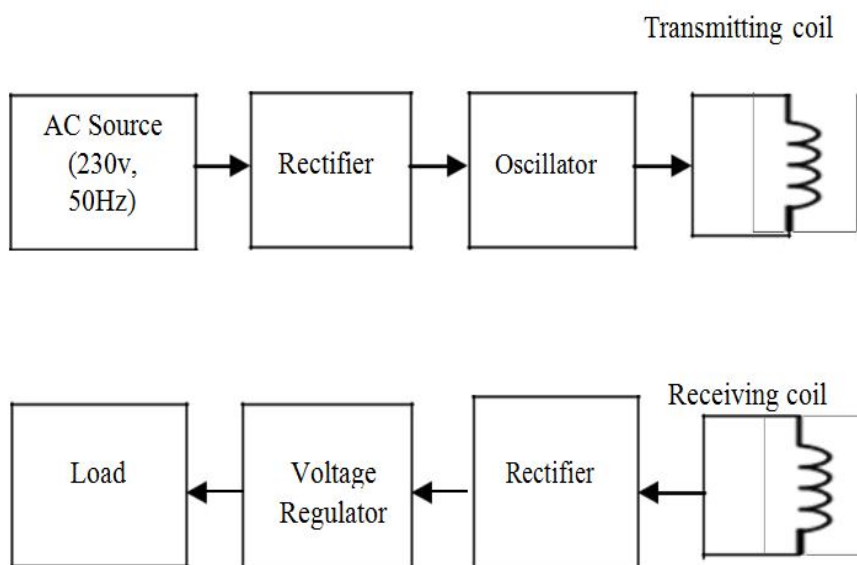

Fig. 1 Basic block diagram of a wireless power transfer

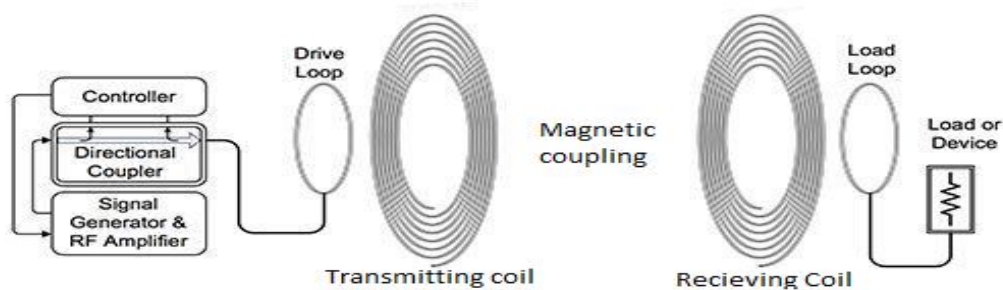

Fig 2- Basic diagram of Resonant coupling

It includes transmitting and receiving coils along with additional capacitances which provide the same resonant frequency to both transmitter and receiver. The transmitting coil converts electrical energy into magnetic energy which is captured by the secondary receiving coil where it is again converted into electrical energy. Every transmitter has a maximum amplifier voltage and current. For maximum power at the receiver, the transmitter should operate at near to the maximum voltage and current.

III.APPLICATION AREAS

A. Transport

- 1) Wireless power exchange is a creative methodology utilizing attractive reverberation coupling of air center transformers intended for the present developing module electric vehicle advertise. This innovation can give an advantageous, sheltered and adaptable intends to power electric vehicles under stationary and mobile conditions. Module electric vehicles are loaded by the need of link and attachment chargers, galvanic seclusion of the locally available gadgets mass and cost of this charger and the expansive vitality stockpiling framework packs required with a framework where you need to physically connect. There are a number of situations when the owner could forget to charge the vehicle. For static applications such as charging of plug-in electric vehicles at home, wireless transfer technology adds a convenient factor compared to mechanical connections.
- 2) Vehicles that travels over a fixed path such as buses and shuttle vehicles, wireless power transfer technology can be used. In the customary framework, the battery backup is intended to oblige the necessities of the whole course or move. With remote power exchange, the battery can be scaled down in light of the fact that it tends to be charged when the vehicle stays on its course. A rental vehicle or transport, for instance, can charge when it holds up at the rental vehicle place. In this manner, the battery just needs enough charge to reach the following stop. This reduction in battery size means considerable cost savings to power the vehicle. This technology enables adept charging station for predefined paths and planned stays reducing charging time [3].
- 3) Luckily, the train is constantly situated just on the rail with minimal vertical and horizontal movement. Thus, the air gap can be decreased to 8 cm, and the instigated voltage is expanded to 186% the WPT framework with 20 cm air gap, where the wirelessly exchanged power can be expanded to 345%. At the point when the electrical cables and pickup curls are distributed in length, the power can reach up to MW range which is essential for fast trains [7].

B. Industrial Applications

- 1) The adoption of wireless power transfer has also maximized production efficiency in the conveyor system of the production line.
- 2) The unmanned wireless powered drone charging station that has been implemented via wireless power transfer technology accelerates the utilization of drones for industrial purposes including unmanned surveillance and logistic transportation.
- 3) The wireless powered LED technology allows us to assemble automotive tail light without cabling, saving cost and improving productivity at the same time.
- 4) A smart automotive window can be powered by wireless power transfer technology which helps the window glass brightening up or darkening. By this extra security and privacy can be maintained while driving.
- 5) The wireless power transfer technology enables an A.V.G. (Automatic guided vehicle) and packaging machines used for the industrial purpose to be automatically charged in a contactless manner while it is stopped in part [4].
- 6) Discovery demonstrates that adequate power for the batteries can be exchanged from the essential to the optional circuits without huge power loss if the working frequency is set somewhere in the range of 50 and 95% of the resonance frequency of the network. The electrical power is then transferred to the chargeable battery which is electrically coupled to the secondary circuit with the help of air core transformer.

C. Medical Applications

- 1) A cardiovascular pacemaker is an electronic medicinal gadget which is utilized to control strange rhythms of the heart. Pacemaker requires a ceaseless supply of power where traditional wires are unreasonably expensive, badly designed, unsafe, costly and inconceivable. Right now, the wearable pacemaker is worked by the installed battery. Be that as it may, the battery has a constrained life and it requires the long-lasting arrangement of vitality. Wireless power supply framework for wearable pacemaker dependent on attractive thunderous coupling can be executed [5].
- 2) The wireless power exchange framework is a rising innovation that is valuable to energize the battery remotely for different compact and biomedical embed gadgets, without battery sensors, latent RF ID, close field interchanges, and numerous others in the close field area [6].

D. Domestic Applications

- 1) The wireless power table allows us to obtain power supply and charge devices wirelessly with no need for power cables, greatly enhancing convenience and space utilization.
- 2) Other domestic devices like mobile phones, TVs, DVD player, and home lighting systems can be powered by a wireless power transfer system.
- 3) In addition, the wireless powered LED technology is met with various toys including plastic models and logo will be able to create unique lighting on top of toys along with exciting pleasure.

E. Wireless Powered Communication Network

Wireless powered communication networking is another efficiently developed system where the battery of wireless communication gadgets can be wirelessly renewed by methods for microwave wireless power exchange method. WPT opens up potential uses of another kind of system, in particular, Wireless powered communication networking, in which every client hub is fuelled by wireless power from passageways. In WPCN, wireless gadgets gather RF flag vitality from the vitality passageway and transmit data to the information passageway by utilizing reaped vitality [9].

F. Military Applications

Several gadgets are being used by soldiers for battle and their own defense. Gadgets used by soldiers or used in manned and unmanned vehicles in the battlefield contains heavy battery backup. The wireless power transfer technology has an efficient quality to help in warfighting in the future. This technology can reduce the burden of heavy battery backups used in warfighting gadgets and vehicles. When the soldiers sit in the vehicles their gadgets such as night vision goggles, radio devices, drones, and anti-fog optics, can be charged from the vehicle seat back. In such a way, all the gadgets can be powered and always ready for operation at any time. Underwater vehicles used for war and defense purposes can be charged by wireless power transfer technology so that they can travel to a larger distance from their mother ship. The reliability of Navy operated underwater vehicles is multiplied by wireless data and energy transfer system. Engineers have proved that several hundred watts of electricity can be transmitted wirelessly through the water. Underwater vehicles can be charged by moving alongside a seaport or some other power source, avoiding the necessity of mechanical coupling. Sensors based military and commercial devices including robotic systems, chemical and biological detectors and surveillance systems can also be charged by laser-based wireless power transfer technology [10].

IV. CONCLUSIONS

In the late 1800s, Nikola Tesla, a brilliant and fascinating scientist proved that electromagnetic energy could be transferred wirelessly. He also stated that in future, all electronic devices would be able to consume power which exists in the space.

But wireless power transfer technology is a long way from flawlessness. The coils still should be contracted down so they can be effectively incorporated into regular gadgets. The separation impediment is a noteworthy blockade, with a field constrained to a couple of meters. The power exchange isn't the most effective procedure. MIT scientists transferred about 45% of the power input, while Intel's ongoing undertaking demonstrated 80% transfer. That sort of intensity loss presents huge obstacle reasonability of these advancements, as vitality isn't free. Wireless power transfer technology is rapidly turning into a practical reality. This innovation offers a very productive option in contrast to past endeavors at demonstrating wireless power.

V. ACKNOWLEDGMENT

We would like to express gratitude toward Mr. Gaurav Srivastava and Dr. Deepika Chouhan for their important direction and productive talks all through the publication of this research paper.



REFERENCES

- [1] Mohammad Shidujaman, Hooman Samani, and Mohammad Arif, "Wireless power transmission trends", 3rd international conference on informatics, electronics & vision, 2014
- [2] Wamalwa Paul Wamboka, "Wireless power transmission", electrical and information engineering, University of Nairobi, May 16, 2016
- [3] (2013) The Youtube website. Available: <https://www.youtube.com/watch?v=Gw6XtzEOlyI>
- [4] (2016) The Youtube website. Available: <https://www.youtube.com/watch?v=BQv219JyafE>
- [5] Vrushali B. Gore and Dhanashri H. Gawali, "Wireless power transfer technology for medical applications", 2016 conference on advances in signal processing (CASP), June 9-11, 2016
- [6] Mr. D.B. Ahire, Dr. Vitthal J. Gond, "Wireless power transfer for biomedical applications: A review", International conference on trends in electronics and informatics ICEI, 2017
- [7] Seung Young Ahn and Dong-ho Cho, "Future wireless power transfer system", 2013 Asia-pacific microwave conference proceedings.
- [8] Arjun Sharma, "Applications of wireless power transfer for home appliances using inductive resonance coupling", International Journal of engineering trends and technology (IJETT)- Volume 16, Number 4, October 2014
- [9] Minh T. Nguyen, Toan H. Nguyen, "Wireless power transfer: A survey of techniques, and applications on communication networks", ICSES transactions on computer networks and communications (ITCNC), Volume 4, Number 4, December 2018
- [10] (2017) The International defense, security and technology website. Available: <https://idstch.com/home5/international-defence-security-and-technology/technology/energy/us-dod-developing-military-wireless-power-transfer-wpt-technology-alleviate-battlefield-battery-burden-soldiers-manned-unmanned-vehicles-land-air-undersea/>



10.22214/IJRASET



45.98



IMPACT FACTOR:
7.129



IMPACT FACTOR:
7.429



INTERNATIONAL JOURNAL FOR RESEARCH

IN APPLIED SCIENCE & ENGINEERING TECHNOLOGY

Call : 08813907089  (24*7 Support on Whatsapp)