



iJRASET

International Journal For Research in
Applied Science and Engineering Technology



INTERNATIONAL JOURNAL FOR RESEARCH

IN APPLIED SCIENCE & ENGINEERING TECHNOLOGY

Volume: 7 Issue: III Month of publication: March 2019

DOI: <http://doi.org/10.22214/ijraset.2019.3268>

www.ijraset.com

Call:  08813907089

E-mail ID: ijraset@gmail.com

Smart Technology in Agriculture System

Swati V. Patel¹, Dr. Satyen Parikh²

¹Assistant Professor, Faculty of Computer Application, Ganpat University, Kherva (North Gujarat), India

²Dean, Faculty of Computer Application, Ganpat University Kherva (North Gujarat), India

Abstract: Agriculture Plays key role in both Employment and country economy as it survive 70% of population and support one third of economy of India. The issues in agriculture become obstacle where good growth of agriculture becomes supportive in growth of nation [1]. The UN projects that two-third of world's population will live in urban areas by the 2050, reducing the rural workforce. The only way that can resolve this issue, is revolutionizing agricultural methods with new technologies [1]. New technologies will be needed to ease the workload on farmers: Operation will be done remotely, processes will be automated, risks will be identified and issue solved. Internet of Things (IoT) can assist to accomplish this. In the future, a farmer's skills will increase by mix of technology.

Keywords: Smart farming technologies, Automation, IoT, Sensors, Controllers

I. INTRODUCTION

India agriculture follows outmoded methods. If Comparing Indian agriculture with other developed nations it is said modern agriculture. The variation is due to the technological usage in agriculture. In India opportunity available for both previous technology and recent technology and the little shift towards technology can open gateway for modern agriculture. The farmer's technical knowledge can become an obstacle to adopting technology in Indian agriculture [12]. The available agricultural lands will have burden to raise production, as global population inclined to cross 9.6 billion up to 2050. World production will have to rise by desirable rate of percentage with respect to production levels of previous years to feed the world population. As availability of agricultural land cannot be increased only the option is to increase efficiency of available agricultural land frame [10].

That is the place where IoT can perform better. Internet of Things (IoT) having a small sensors that can place to anywhere to analyze humidity or moisture, pressure, brightness, temperature, presence of chemical or gas flow. IoT can fortunate the farming community to get revolved. IoT can assist farmers and agriculturists by collecting precise data of crop health, soil fertility, weather prediction and many more. These data can be modeled that will enables farmers for planning smart techniques and methods for farming that leads to maximize crop productivity of available agricultural land in equal time period. Some options here show how IoT will make its space into agriculture in forthcoming years [10].



Fig. 1 Smart farming Technologies

II. DIFFERENT TECHNOLOGY FOR SMART FARMING

A. Smart Irrigation

In agriculture water management is biggest issue. By using a traditional watering systems water wastage can't be stopped. Farmer should moves to smart solutions for better water management. Smart irrigation is helpful in both: One It reduces the water scarcity as it save the water by controlling wastage of water and other is it Reduce the manual intervention to operate it.

One study said that in the United States, the use of outside water alone averages more than 9 billion gallons of water per day, mostly for watering gardens. Up to 50% of this water is become unused due to excessive irrigation; reason is inadequacies in traditional technique and irrigation systems. The only way to resolve this problem is use of Smart irrigation techniques [11].

Systems Intelligent irrigation systems adapt irrigation programs and run times automatically to meet the precise needs of the soil. Such controllers expressively increase the effectiveness of outside usage of water [11].

Smart irrigation sensors monitors weather, soil conditions, evaporation, and plant water usage and controller automatically adjusts the water supply strategy to the real position of the place with a preset program and timer it is different from conventional irrigation controllers that work with [11].

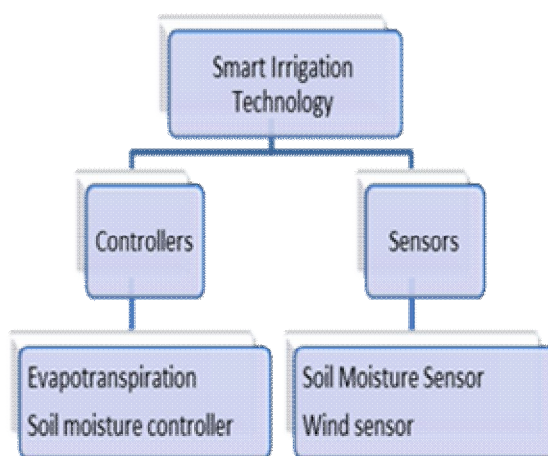

Fig.2 Controller and Sensors in Smart Irrigation

For instance, as outdoor temperatures rise or rain decreases, smart irrigation controllers consider place-specific variables like kind of land, watering level, etc. The varieties of smart irrigation controllers are available [11].

B. Seed Planting, Crop Growth and Health Monitoring

The future is very challenging to achieve food demands of increasing population. Day by day agricultural land is decreasing and food demand is increasing. To balance this situation production rate should be increased at a best level in available land. To get better productivity care should be taken for all the phases of crops.

IOT plays a good role in every phase. By incorporating the technologies like Image processing and Drone technology with the IOT, crop management become more precise.

Technology can be used at the different Phases as mentioned below.

- 1) *Seed Planting:* With the help of drone actual image of farm can be taken. According to farm area and types of crop planting distance can be decided and equal distance can be managed. It helps to precise mapping of field. Planting using drone is also a realization of technology which helps farming. It will reduce the cost and time. These systems sprout shells with seeds and nutrients into the soil, it deliver all the required nutrients to grow crops. [6,9]
- 2) *Crop Scanning:* Drone or cell phone can be used to take image of crop. By using image processing digital image can be generated for further processing. It helps to get the crop growth stages, changes in colour of crop; insect in crops, which type of disease is infecting the crop and by getting this data farmer is able to identify the required fertilizer and pesticide to control the insects. This is helpful for planting and managing irrigation and nitrogen levels [9].

3) *Crop Spraying*: Due to the high-end camera drone is able to detect the insect and with the help of IoT, proper pesticide is decided. Also, it can be sprayed by drone to affected area, which result cost and time is saving [9].

C. Smart Harvesting

Robots are used to harvest a farm. By camera it capture image and recognize the colour and shape of crop. By getting information from server robots with arms and wheel can perform a better in harvesting.

With the Use of IoT sensors, harvest statistics can be collected and analysed for production forecasting.

D. Sensors to Obtain Soil Data

1) It is difficult to observe soil data in a large size farm land. Generally farmers used sampling methods, which give approximation about fertility, moister of soil. But such technique repeatedly gives false results. Types of soil and consistency of soil levels are also different for different land.

2) IoT helps to be more specific in farming. Sensors can be deployed at even levels in all over the farm. Different types of sensors are available with different capacity, different cost and with different usage. Every sensor deployed in a farm collects the soil data like moisture, a type of soil, Organic structure of soil. Data are collected to server and used to take certain decisions to maintain soil quality and it gives the precise results.

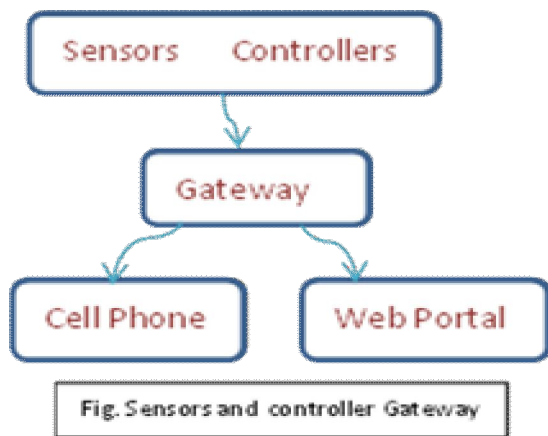

3) By use of sensors desired water level and required fertilizers can be predicted and leads to serve better quality of soil and better productivity

4) As fig 1. shows there are different kind of controllers like Evapotranspiration and Soil moisture controller are available and different type of sensors to major soil moisture and wind sensors are available.

5) Example of soil moisture sensor

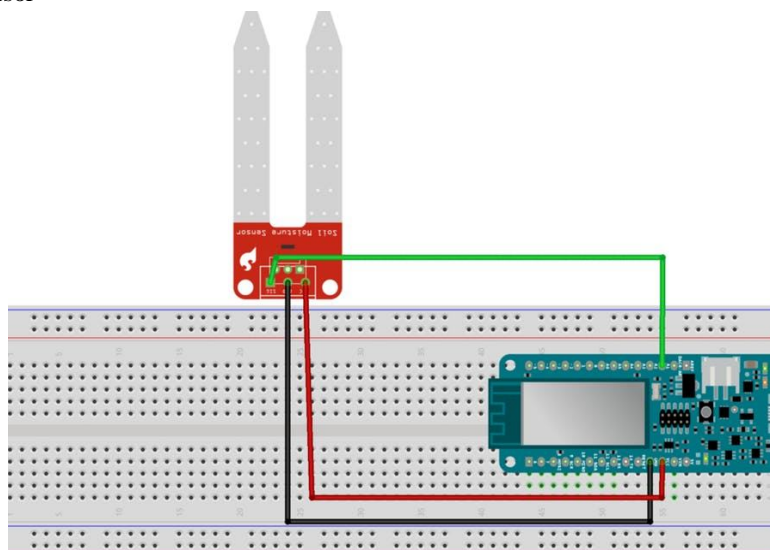

Fig.4 Soil Moisture Sensor

E. Smart Tractors

- 1) As day by day urban development is increasing, the scarcities of skilled labor specifically in rural areas are increasing. For farmers buy a tractor become easy than hiring people. Now a day's tractors also become automated.
- 2) The smart tractor uses GPS or any other similar technology to plant, which helps to avoid the overlapping of excesses or the sowing through water courses.

III. ADVANTAGES OF TECHNOLOGY IN AGRICULTURE

As machines are working in farm less man power is required so it is reduce the farmer's efforts and save time. It became profitable in many aspects like:

- A. Smart and automated irrigation that save time, money and reduce water wastage.
- B. Drones are used for seeding.
- C. Growth of crop can be monitored from anywhere.
- D. Fertilizers and pesticides can be sprinkles without using human resource.
- E. Insects or any other bugs can be finding out on time.
- F. Robotics can be used for harvesting.
- G. As it increases productivity it is cost effective.

IV. BARRIERS IN ADOPTION OF TECHNOLOGY IN AGRICULTURE

- A. Lack of incorporation among system: A suitable technological infrastructure is essential to incorporate different technology which can be a challenging [14].
- B. Education and awareness of farmers and low technical level of farmer: In India still farmer education becomes a key change in adoption of novel farming technology in India [15].
- C. Poor network infrastructure in rural areas: Every smart system deal with a network to operate it automatically or from remotely. Availability of network infrastructure in becomes a key issue[14]
- D. Difficulty with data manipulation from equipment machines and software: The unstructured, mixed data which requires an interaction between skilled data experts and domain experts [14].
- E. High costs to adopt technology for individual farms are still the most significant issue in agriculture especially in developing countries [15].

V. APPLICATION FOR FARMING

- A. From the advantages discussed in this paper it can be stated technology is essential in farming by mean of country growth. It can be a helpful to make ease in farmers life also.
- B. From barriers given in this paper we can state that technology for farming should be less costly and should be easy to understand by farmers.

VI. CONCLUSION

The application of smart technologies is the need of modern agriculture, also a gateway of future farming. It can be lead the agriculture from rural society to urban society. In future land and water resources will be limited compare to human population. IoT helps to increase productivity with less water, less man power and in less time which is a necessity of future farming.

REFERENCES

- [1] Gondchawar, Nikesh, and R. S. Kawitkar. "IoT based smart agriculture." International Journal of Advanced Research in Computer and Communication Engineering (IJARCCE) 5, no. 6 (2016): 177-181.
- [2] Pivoto, Dieisson, Paulo Dabdab Waquil, Edson Talamini, Caroline Pauletto Spanhol Finocchio, Vitor Francisco Dalla Corte, and Giana de Vargas Mores. "Scientific development of smart farming technologies and their application in Brazil." Information processing in agriculture 5, no. 1 (2018): 21-32.
- [3] Zhao, Ji-chun, Jun-feng Zhang, Yu Feng, and Jian-xin Guo. "The study and application of the IOT technology in agriculture." In Computer Science and Information Technology (ICCSIT), 2010 3rd IEEE International Conference on, vol. 2, pp. 462-465. IEEE, 2010.
- [4] Gayatri, M. K., J. Jayasakthi, and GS Anandha Mala. "Providing Smart Agricultural solutions to farmers for better yielding using IoT." In Technological Innovation in ICT for Agriculture and Rural Development (TIAR), 2015 IEEE, pp. 40-43. IEEE, 2015.
- [5] Shenoy, Jeetendra, and Yogesh Pingle. "IOT in agriculture." In Computing for Sustainable Global Development (INDIACom), 2016 3rd International Conference on, pp. 1456-1458. IEEE, 2016.



- [6] Lakshmi, K., and S. Gayathri. "Implementation of IoT with Image processing in plant growth monitoring system." *Journal of Scientific and Innovative Research* 6, no. 2 (2017): 80-83.
- [7] Lee, Meonghun, Jeonghwan Hwang, and Hyun Yoe. "Agricultural production system based on IoT." In *Computational Science and Engineering (CSE), 2013 IEEE 16th International Conference on*, pp. 833-837. IEEE, 2013.
- [8] Cai, Ken. "Internet of things technology applied in field information monitoring." *Advances in Information Sciences and Service Sciences* 4, no. 12 (2012).
- [9] Matthieu De Clercq, Anshu Vats, Alvaro Biel "Agriculture 4.0 The Future of Farming Technology." *Worldgovernmentsummit* Feb 2018.
- [10] Web content available at suyati.com
- [11] Web content available at hydropoint.com
- [12] Web content available at agrihealthfoods.com
- [13] Web content available at studymode
- [14] Wolfert, Sjaak, Lan Ge, Cor Verdouw, and Marc-Jeroen Bogaardt. "Big data in smart farming—a review." *Agricultural Systems* 153 (2017): 69-80.
- [15] Walter, Achim, Robert Finger, Robert Huber, and Nina Buchmann. "Opinion: Smart farming is key to developing sustainable agriculture." *Proceedings of the National Academy of Sciences* 114, no. 24 (2017): 6148-6150.
- [16] Rani, M. Usha, and S. Kamallesh. "Web based service to monitor automatic irrigation system for the agriculture field using sensors." In *Advances in Electrical Engineering (ICAEE), 2014 International Conference on*, pp. 1-5. IEEE, 2014.



10.22214/IJRASET



45.98



IMPACT FACTOR:
7.129



IMPACT FACTOR:
7.429



INTERNATIONAL JOURNAL FOR RESEARCH

IN APPLIED SCIENCE & ENGINEERING TECHNOLOGY

Call : 08813907089  (24*7 Support on Whatsapp)