



# **iJRASET**

International Journal For Research in  
Applied Science and Engineering Technology



---

# **INTERNATIONAL JOURNAL FOR RESEARCH**

IN APPLIED SCIENCE & ENGINEERING TECHNOLOGY

---

**Volume: 7      Issue: III      Month of publication: March 2019**

**DOI: <http://doi.org/10.22214/ijraset.2019.3433>**

**[www.ijraset.com](http://www.ijraset.com)**

**Call:  08813907089**

**E-mail ID: [ijraset@gmail.com](mailto:ijraset@gmail.com)**

# Smart Power Source Selector using GSM

Pooja kalal<sup>1</sup>, K. Pratibha<sup>2</sup>, Pooja M Agnihotri<sup>3</sup>, Bhanushree.T<sup>4</sup>, Hanumantha Reddy<sup>5</sup>, Rajashekar K<sup>6</sup>  
<sup>1,2,3,4</sup>Under Graduate Scholar, <sup>5,6</sup>Assistant Professor, Department of Electrical and Electronics Engineering,  
Rao Bahadur Y Mahabaleswarappa Engineering College, India

**Abstract:** The main motto of this project is to provide continuous power supply to a load, by an appropriate selection of the supply from any of the four sources (i.e, solar, wind, main and generator) automatically in case if one of the source is absent. Thus there is requirement for an auxiliary arrangement of power supply. This arrangement can be designed by using 89C51 microcontroller and relays. When a source, say solar fails the supply automatically shifts to next priority source wind and so on. LED's (light emitting diodes), d. c, fan can be used to show that which source is used to provide the supply. An alternative arrangement for power source is a must. In this project uses four switches to create respective failure of that power supply. When any of the switches is pressed it shows that the source is absent, switches are connected to a microcontroller as input signals. A microcontroller of 8051 family is used. The output signal of microcontroller is given to the ULN 2003. Which switches appropriate relay to maintain continuous supply to the load. On the failure of solar supply (which is actuated by pressing the appropriate switch) the load gets supply from the next available source, say a wind. If the wind also fails it switches over to the next available source and so on. The current status, as to which source supplies the load is also displayed on an LCD.

## I. INTRODUCTION

The main objective of this project is to provide uninterrupted power supply to a load, by selecting the supply source automatically from any available one out of such as: mains, generator, inverter and solar in the absence of power supply. The demand for electricity is increasing every day and frequent power cut is causing many problems in various areas like industries, hospitals and houses alternative arrangement for power supply is thus desirable.

In this project uses four switches to demonstrate the respective failure of that power supply. When any of the switches is pressed it shows the absence of that particular source, switches are connected to microcontroller as input signals. A microcontroller of 8051 family is used. The output of microcontroller is given to the relay driver IC, which switches appropriate relay to maintain uninterrupted supply to the load. The output shall be observed using a lamp drawing power supply from mains initially. On failure of the mains supply (which is actuated by pressing the appropriate switch) the load gets supply from the next available source, say an inverter. If the inverter also fails it switches over to the next available source and so on. The current status, as to which source supplies the load is also displayed on an LCD. This will avoid the problem of interruption of the supply. Additionally we have implemented a GSM modem, where the user can make a switching from remote location with the help of mobile handset, it will also give a feedback status of current running source. Thus it will be more reliable and convenient to user to operate multi power supply.

## II. PROBLEM STATEMENT

Designing a smart automated device which controls the switching of power supply of four different sources, the system can be operated automatically as per the given commands and also the user can control the system by a mobile application or by switches.

## III. LITERATURE REVIEW

[1] According to Shahaji Dhudate (2016,) there is requirement for an alternate arrangement of power supply. When a source, say mains interrupt the supply automatically shifts to next priority source generator and so on. LEDs can be used to show that which source is used to provide the supply [1] we made use of GSM technology, which helps in operating the system from the different places. This GSM technology is the latest technology, which is use to collect the information about the different sources either the switch is ON or OFF and load is ON or OFF. In this system, we made use of Microcontroller 89c52 which has many advance features than 8051 microcontroller family [1]

[2] According to Amuzuvi, C. K. and Addo, E. (2015) A Microcontroller-Based Automatic Transfer Switching System (MBATSS), which eliminates challenges of a manual changeover system. A voltage sensing circuit, a Hall Effect current sensor, relays, LEDs and an LCD were all coordinated using a 89c52 microcontroller. A system was developed for the firmware and the microcontroller programmed using Keil microvision programming software [2] This paper reports on the design of system an efficient

microcontroller-based ATS making use of relays, voltage and current sensing circuitry, a display unit and an alarm unit in order to reduce the circuit's power consumption, operate fast, reduce component count and considerably reduce cost.

[3] In the paper of KESHINRO K. K1 (2016) They reports on the design of an efficient microcontroller-based ATS making use of relays, voltage and current sensing circuitry, a display unit and the alarm unit in order to reduce circuit's power consumption, operate fast, reduce component count and considerably reduce the cost.[3] .Thus for literature review we referred some of above paper which gives some idea to us, which will definitely helpful to us another some papers references are very helpful and give some knowledge for us.

#### IV. METHODOLOGY

The system uses four different power sources. Out of four, one source will provide power to load. When ongoing source will fail, then other source come in role, and continuing its working. Here the mechanism of switching is important, because it should be uninterrupted. So here we discuss a commonly used switching mechanism.

#### V. WORKING

This project uses an arrangement of four different sources of supply which are channelized to a load so as to have an uninterrupted operation of the load. As it is not practicable to get four sources of supply such as solar supply, inverter supply, main supply and generator supply, we used one source and a set of relays. We have taken first source with solar supply and assumed as if being fed from four different sources by connecting all the four incoming sources in parallel. The ac source to the lamp is connected to four relays by making the entire normally open contacts parallel and all the common contacts in parallel. Four push button switches are used which represent failure of corresponding supply respectively and are interfaced to the controller. Initially we have given high input signal to the

microcontroller, so as a result the controller generates a low output to activate the first relay driver which will result in the relay being energized and the lamp glows. While the push button for solar is pressed that represents failure of solar supply as a result the supply is provided from the next source and the microcontroller receive high input and generates low output to activate the second relay driver which will result in the second relay being energized and the lamp glows . When we press the inverter button, it indicates the inverter or fails to operate and the supply comes from the next source and the next source will supply high input to the controller and which Will provide low signal to the third relay and the lamp switches ON and when we press the third push button the supply will chose next source now the fourth source will provide input to the microcontroller and controller activates the fourth relay and the load will get the supply and the lamp continues to glow. When all the relays are off leaving no supply to the lamp, the lamp is switched off. One 16 x 2 lines LCD is used to display the condition of the supply sources and the load on real time basis. The microcontroller runs the relay driver circuitry which ultimately drives the multiple load. GSM module is connected to microcontroller via RS-232 communication standard GSM module is connected for wireless switching from remote location. User can control load and the sources via mobile phone.

#### VI. BLOCK DIAGRAM

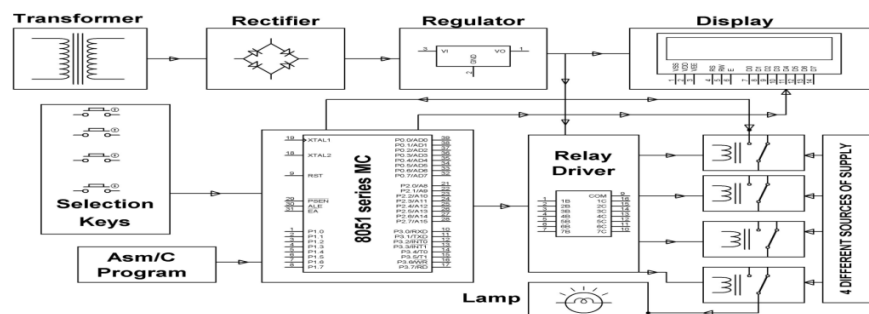

#### COMPONENTS

Transformer

- Bridge Rectifier
- Voltage Regulator
- LCD Display
- Selection keys
- PIC Microcontroller 8051
- Relay Driver
- Load
- RS-232
- GSM Module

## VII. COMPONENTS DESCRIPTION

### A. Transformer:

In this auto power supply control system, the transformer is used for connecting this system directly to the 220V ac. It steps down the 220V ac into 12V ac .it consists of two windings and work on the principle of mutual induction.

### B. Bridge Rectifier:

In this auto power supply control system, the bridge rectifier is used for converting the 12V ac voltages into dc voltages for supplying the power to the other electronics components.

### C. Voltage Regulator:

In this auto power supply control system, the voltage regulator is used for regulating the 12V dc voltages into 5V dc voltages for supplying the power to the LCD display, microcontroller and relay driver IC. In this system LM 7805 voltage regulator is used for regulating the bridge rectifier the voltages.

### D. LCD Display:

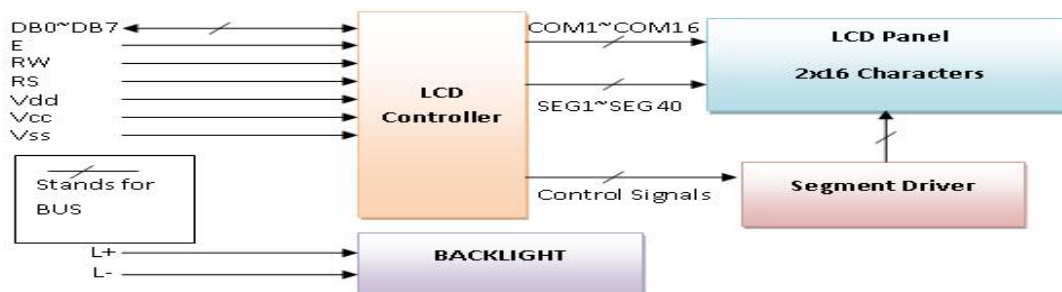

It is a very basic model and it is very commonly used in various devices and circuits. A 16\*2 LCD means it can display 16 characters per line and there are two such lines .In this LCD each character is displayed in 5\*7 pixel matrix. This LCD has two registers, namely, command and data. It has 14 pins. It uses 8 lines (D0-D7) for parallel data plus 3 control pins(register select (RS),read/write(R/W),enable(E)), 2 connections to power, one more for contrast adjustment and two connections for LED back light.

### E. Selection Keys:

In this auto power supply control system, the selection keys are the basically push buttons which are used for checking the working function of this system. These are pushed up one by one for demonstration purposes.

### F. Microcontroller (89C52):

Features:

- 1) Fully static design 8 bit CMOS microcontroller

- 2) Optional 12T or 6T mode
- 3) Wide supply voltage of 2.4V to 5.5V
- 4) Temperature grade is (-45c~85c)
- 5) Pin and instruction-sets compatible with MCS-51
- 6) 256 bytes of on-chip scratchpad RAM
- 7) 16K/8K/4K bytes electrically erasable/programmable flash EPROM
- 8) 2K bytes LDRAM support ISP function
- 9) 64KB program memory address space
- 10) 64KB data memory address space
- 11) Four 8-bits bi-directional ports
- 12) 8-sources ,4-level interrupt capability
- 13) One extra 4-bit bit-addressable I/O port, additional INT2/INT3(available on PQFP,PLCC and LQFP packages)
- 14) Three 16 bit timer or counter
- 15) One full duplex serial port
- 16) Watch dog timer
- 17) EMI reduction mode
- 18) Software reset

Pin configuration

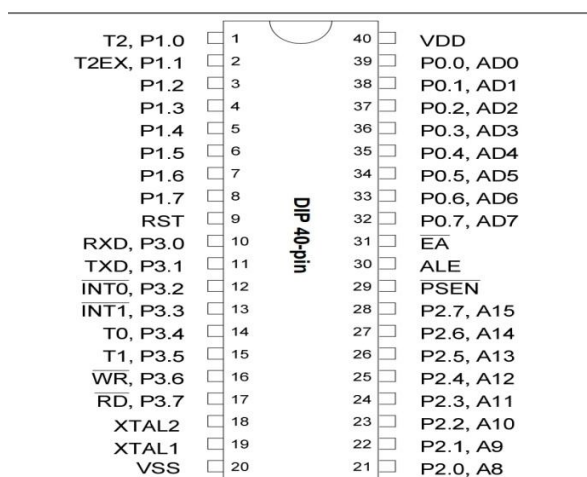

G. Relay Driver:

In this auto power supply control system, the relay driver IC is used for driving the load relays. This relay receives the signal from microcontroller for shifted the load on another supply source. It is powered up with 5V dc and interfaced with microcontroller.

H. Load:

In this auto power supply control system, the lamp is used here as an output load for demonstration purposes.

I. RS- 232:

For interfacing of GSM module to microcontroller, we use a serial communication protocol which is RS-232.



RS 232 includes MAX 232 and DB-9 connectors. Out of that MAX 232 is used to convert TTL logic voltage levels of

microcontroller 89c52 (logic 0-0v, logic1-5v) into voltage levels of RS-232 standards. MAX-232 is a dc to dc converter, which takes TTL levels, which are required for the DTE to DTE communication. RS-232 is asynchronous communication. That is the clock signal is not sent with the data. Each word is synchronized using its start bit, and the internal clock on each side, keeps tabs on the timing level. The RS-232 levels are generated internally using switching latches and capacitors of 10uf of each.

#### J. GSM Module:

The GSM Module is interface with microcontroller 89c52 through MAX 232. GSM Module have a SIM card, it sends an SMS to user, when an error introduced.

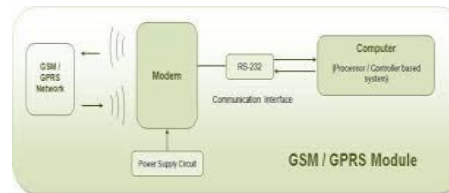

#### 1) GSM Features:

E-GSM 900/1800 MHz with GSM Phase 2 / 2+

Output Power Class 4 (2W) at GSM 900 MHz and Class 1 (1W) at GSM 1800MHz

Control via using AT commands (ITU, GSM, GPRS and the manufacturer supplementary)

Supply Voltage Range: 3.4 V - 4.2 V, nominal: 3.8 V

Power consumption: Idle mode: <3.5 mA, speech mode: 250 mA (average)

Dimensions (mm): 6 x 43.9 x 43.9 and weight (g): 20 (including shielding)

#### 2) GSM Interfaces:

Power supply nominal 3,8 Volt

7 general purposes I/O ports and serial bi-directional bus on CMOS 2,8 V

Internal / External SIM 3 / 5V

Analog audio for the microphone, speaker and hands free set

RS232 on CMOS 2,8 V (One RS232 (2,8V) with flow control (RX, TX, CTS, RTS, CTS, DTR, DSR, DCD, RI), baud rate is 300 - 115.200 bps, autobauding 1200 - 57.600 bps

50 Ohm antenna connector (900 and 1800 MHz)

### VIII. ADVANTAGES

- A. This system could be used in that places where we have different sources of supply such as solar, main and wind.
- B. This system could be used in industries for supplying the uninterruptable power supply to the industrial machines.
- C. This system could be used in educational institutes and hospitals for supplying the uninterruptable power supply to the hospital or educational equipment.
- D. This system is more compact and reliable as compared to the electrical ATS panels.
- E. This system is less costly as compared to the other power control systems.

### IX. APPLICATIONS

Power supply can be controlled in:

- Industries
- Hospitals
- Schools
- Multiplexes
- Banks etc.

### X. CONCLUSION

The main objective of this project is to provide an "Smart power source selector using GSM". It has been developed by integrating features of all the hardware and software components. Presence of every module has been reasoned out and placed carefully thus contributing to best working of the unit.





This project provides a continuous power supply to the output load through any of the source using GSM Module, in order to provide both manual & automatic switching of the power supply. The project also provides the best possible power at the lowest cost.



### REFERENCES

- [1] Mr.Shahaji Dudhate, Mr.Amol Attargekar, Mr.Dhanaji Desai, Prof. Mrs.Aditi Patil "Power Supply Control from Different Sources" International Journal of Scientific & Engineering Research, Volume 7, Issue 1, January-2016 484 ISSN 2229-5518.
- [2] Amuzuvi, C. K. and Addo, E. (2015), "A Microcontroller-Based Automatic Transfer Switching System for a Standby Electric Generator", Ghana Mining Journal, Vol. 15, No. 1, pp. 85 – 92.
- [3] KESHINRO K. K1., BALOGUN W. A2, OYETOLA J. B3., OMOGOYE S. O4 "Design and Development of SMS Based Generator Start/Stop System" American Journal Of Engineering Research .(AJER) e-ISSN: 2320-0847p-ISSN : 2320-0936 Volume-5, Issue-3, pp-01-06
- [4] L. Theraja and B. K. Theraja. A textbook of Electrical Technology.S. Chand And Company Ltd. New Delhi, India 2002 pp. 220, 920, 924, 1712 –1716.
- [5] Bernard Grob and Mitton S. Kiver. Application of electronics. Syed Sons Printer. Lahore. 1985 pp 162-167, 171, 174.
- [6] Mr. Vikas S. Chandre 1, Prof. Ravindre G. Dabhade2" Smart Grid System To Monitor and Control Renewable Energy Source Based on Web of" Vol-2 Issue-4 2016 IJARIE-ISSN(O)-2395-4396

### ABOUT AUTHORS

	<p>Mr. RAJASHEKAR.K B.E. (Electrical and Electronics), Rao Bahadur Y Mahabaleswarappa Engineering College(vtu) M.Tech (digital electronics), BITM(vtu) Email-rajashkekark22@gmail.com</p>
	<p>Mr. HANUMANTHA REDDY B.E. (Electrical and Electronics), Rao Bahadur Y Mahabaleswarappa Engineering College(Vtu) M.Tech (Power electronics), P.D.A (kalaburgi) Email-reddysham16@gmail.com</p>
	<p>Ms. POOJA KALAL B.E(Electrical And Electronics),Rao Bahadur Y Mahabaleswarappa Engineering College(vtu) Email-poojakalal.rymec@gmail.com</p>



	<p>Ms. K PRATIBHA B.E(Electrical And Electronics),Rao Bahadur Y Mahabaleswarappa Engineering College(vtu) Email-pratibha43eee.rymec@gmail.com</p>
	<p>Ms. POOJA M AGNIHOTRI B.E(Electrical And Electronics),Rao Bahadur Y Mahabaleswarappa Engineering College(vtu) Email-poojaeee.rymec15@gmail.com</p>
	<p>Ms. BHANUSHREE T Email-bhanu24eee.rymec@gmail.com B.E(Electrical And Electronics),Rao Bahadur Y Mahabaleswarappa Engineering College,BELLARY</p>





International Journal for Research in Applied Science & Engineering Technology (IJRASET)

*ISSN: 2321-9653; IC Value: 45.98; SJ Impact Factor: 6.887*

*Volume 7 Issue III, Mar 2019- Available at [www.ijraset.com](http://www.ijraset.com)*



10.22214/IJRASET



45.98



IMPACT FACTOR:  
7.129



IMPACT FACTOR:  
7.429



# INTERNATIONAL JOURNAL FOR RESEARCH

IN APPLIED SCIENCE & ENGINEERING TECHNOLOGY

Call : 08813907089  (24\*7 Support on Whatsapp)