



# IJRASET

International Journal For Research in  
Applied Science and Engineering Technology



---

# INTERNATIONAL JOURNAL FOR RESEARCH

IN APPLIED SCIENCE & ENGINEERING TECHNOLOGY

---

**Volume: 7      Issue: IV      Month of publication: April 2019**

**DOI: <https://doi.org/10.22214/ijraset.2019.4130>**

**[www.ijraset.com](http://www.ijraset.com)**

**Call:  08813907089**

**E-mail ID: [ijraset@gmail.com](mailto:ijraset@gmail.com)**

# CERES-An Autonomous and Versatile Agriculture Robot

Arpitha N V<sup>1</sup>, Abhishek S Gowda<sup>2</sup>, Akshaya Ram Badala<sup>3</sup>, Chethan N Shetty<sup>4</sup>, <sup>5</sup>Jayasudha BSK

<sup>1, 2,3,4</sup>K S Institute of technology, India

<sup>5</sup>Assistant Professor, K S Institute of technology, India

**Abstract:** *In recent years, robotics in agriculture sector with its implementation based on precision agriculture concept is the newly emerging technology. The main reason behind automation of farming process are saving the time and energy required for performing repetitive farming tasks and increasing the productivity of yield by treating every crop individually using precision farming concept. Designing of such robots is modeled based on particular approach and certain considerations of agriculture environment in which it is going to work. A robot capable of performing operations like automatic ploughing, seed dispensing and pesticide spraying is developed. It also provides manual control when required and keeps tabs on the humidity with the help of humidity sensors. The main component here is the ARM 7 microcontroller LPC2148 that supervises the entire process. Initially the robot tills the entire field and proceeds to ploughing, simultaneously dispensing seeds side by side. The device used for navigation is an ultrasonic sensor which continuously sends data to the microcontroller. On the field the robot operates on automated mode, but outside the field is strictly operated in manual mode. For manual control the robot uses the zigbee or wifi modules as control device and helps in the navigation of the robot outside the field. The field is fitted with humidity sensors placed at various spots that continuously monitor the environment for humidity levels. It checks these levels with the set point for humidity and alerts the farmer.*

## I. INTRODUCTION

**Agriculture in India** dates back to Indus Valley Civilization Era and even before that in some parts of Southern India. India ranks second worldwide in farm outputs. Agriculture and allied sectors like forestry and fisheries accounted for 15.4% of the GDP (gross domestic product) in 2016 with about 31% of the workforce in 2014. India ranks first globally with highest net cropped area followed by US and China.

The economic contribution of agriculture to India's GDP is steadily declining with the country's broad-based economic growth. Still, agriculture is demographically the broadest economic sector and plays a significant role in the overall socio-economic fabric of India. In recent years the agro sector has faced a severe brain drain due to its low fiscal turn over and its tedious fabric of work. With the advent of 20<sup>th</sup> century many age old practices underwent a digital upgrade. Our project aims for such a revolution in this anachronistic field which is the backbone of our society.

Many agriculture operations are automated nowadays and many automatic machineries and robots available commercially. Some of the major operations in farming which are under research and automation are seeding, weeding and spraying processes. When it comes to designing a robot for automating these operations one has to decompose its idea into two considerations which are agriculture environment in which robot/system is going to work and precision requirement in the task over traditional methods. Based on this for seeding process, considerations which are taken into account in terms of environment are: robot must be able to move in straight away properly on bumpy roads of farm field, soil moisture content may affect the soil digging function, sensors to be selected for the system must be chosen by considering farming environmental effects on their working. Apart from these three other requirements are in terms of accuracy required in the task and these are: digging depth, particular optimal distances between rows and plants for certain type of crop, rows to be sown at a time and accurate navigation in the field. Whereas the other processes like weeding, spraying and harvesting, for which functioning depends on seeding stage by knowing the exact location of crop and then making those operations on it accordingly. So the major stage of all subsequent operations is maintaining a precision in seed sowing process.

When considering the physical aspects of the vehicle or robotic system, farmer's present condition in particular area plays a major role in designing these aspects. Considering facts of farming industry of India, system to be developed must have advantage over traditional methods and tractors in terms of cost, speed, accuracy in operation for which it is designed, fuel consumption and

physical energy required by human for it. By targeting these issues and considerations properly the end product will be real help for farmers.

#### A. Image Processing for Disease Detection

In engineering that makes use of digital signal processors, image processing is one form of signal processing for which the input is an image, such as a photograph or video frame. The output of image processing may be either an image or a set of characteristic related to the image. Most of the image processing techniques treat the image as a two-dimensional signal and applying standard signal processing techniques to it like noise rejection, gray scaling etc. An image is an array or a matrix of square pixels that are picture elements arranged in columns and rows. It can also be defined as a two dimensional function  $f(x, y)$  where  $x$  and  $y$  are spatial coordinates, and the amplitude at any pair of coordinates  $(x, y)$  is called the intensity or gray level of the image processed at that point.

## II. LITERATURE SURVEY

- 1) Future Precision Autonomous Farming (PAF) is the main area of focus. It also emphasizes on the preferred specification of the farming systems which include farming system layout, sensing systems and actuation units such as tractor-implement combinations. The Precision Farming Data Set (PFDS) which is formed off-line before the commencement of the crop cultivation and discusses its use in accomplishing reliable, cost effective and efficient farming systems is proposed. Emphasis on the need to introduce a strict structure and the importance of taking into considerations the farm system parameters in developing an *a priori* Precision Farming Data Set which is continuously being used by each precision autonomous farming unit was done. Thus it mainly aims in increasing the PAF and PDFS methods of agriculture.
- 2) The development of many countries is affected due to the lack of skilled labour in the agriculture field. In order to overcome this problem there are many alternatives that are being presented. Thus an idea of automating the process of sowing crops such as sunflower, baby corn, groundnut and vegetables like beans, lady's finger, pumpkin and pulses like black gram, green gram etc have be proposed to reduce the human labour, thus increasing the yield. The plantations of seeds are automatically done by using DC motor. Microcontroller is used to control and vary the distance between two seeds depending on the kind of seed used. The direction of the switch can be varied when the robot reaches the end of the cultivation land. Thus an idea of reducing human labour and increasing yield by making use of microcontroller in the required calculations id implemented.
- 3) A new way of advancement in process such as cultivation on ploughed land is introduced, based on robotic platform. A robotic vehicle with four wheels and steered DC motor is developed. The cultivation is done by the robot, automatically taking into account the obstacles that occur in the field. Also, the distance between the seeds to be sowed is calculated. While calculating, particular rows and specific columns are considered. The whole algorithm, calculation, processing, monitoring are designed with motors & sensor interfaced with microcontroller. Feed forward and feedback technique by simulation of DC motor gives precise output. There are two mechanisms involved here, building a robot that can handle the process and second is preparing a seed bed on ploughed land.
- 4) A robot capable of performing operations like automatic ploughing, seed dispensing, fruit picking and pesticide spraying is developed. The robot has many additional features such as manual and automatic control. AVR atmega is the main component used in controlling the entire process. The robot tills the entire field and proceeds to ploughing, simultaneously dispensing seeds side by side. On the field the robot operates on automated mode, but outside the field is strictly operated in manual mode. Manual mode is achieved by using Bluetooth pairing app. The farmers are informed about the humidity level by the sensors placed at different places on the field through the GSM module. The water sprinklers, if on, bring down the humidity level thus providing an ideal growing environment to crop.
- 5) Many technologies are working on a new automation work which helps to increase the efficiency within a short duration of time. Agriculture is a sector of raising demands every day. Thus, any progress in the agriculture sector provides good response and high quality of products. The new progress is done by designing a robot that performs seeding and fertilizing, which is controlled by the microcontroller. The robot is also able to sense the soil ph, temperature, moisture and humidity level. The robot works in manual mode i.e., it is controlled with the help of a remote. Once the robot reaches the destination, it starts performing the above mentioned operations. Seeding and fertilizing are controlled by solenoid.
- 6) An automatically guided tractor was designed in order to support the navigation system. John Deere tractor was considered as the base and a new bicycle model of the tractor was implemented in the MATLAB environment. Field navigation test was conducted to validate the new MATLAB model. There were certain experiments performed in order to check the accuracy of the tractor at the corners of the field. It was done by recording the trajectory data of the MATLAB model. The obtained results proved that the tractor could estimate the wheel trajectories accurately, while operating in agriculture fields at different speeds. The results also showed that the tractor velocity could also be determined along with the steering angle while the tractor operates in curved fields. Thus a system which could reduce a bi of human labor and overcome the time constraint was developed. The new tractor was designed to perform all these tasks.

- 7) A tractor that works as a generic mobile platform is developed. This paper presents the hardware and software architecture of such tractors. The main task that is being performed is fruit picking. Such systems require precision outdoor maneuvering and coordination with the implement attached to the vehicle. The fruits that are picked are loaded on the loader that is attached at the front of the tractor. This paper performs only the fruit picking operation once all the other process are successfully completed.
- 8) The important task to be performed after the plant growth is the disease detection. The identification and prevention of disease that affects the plant is the major factor that increases the yield. The study of plant diseases means the study of the patterns seen in the plants. The disease detection of the plants is a tedious job, if done manually. The recognition of the disease involves a lot of skill and experts in such field. It is also very time consuming. Hence, image processing is a very good option for disease detection. Disease detection involves steps such as image acquisition, image preprocessing, image segmentation and feature extraction. The images of the leaves are captured and based on the pattern of the leaf, the disease is detected.
- 9) The studies of plant trait/disease refer to the studies of visually observable patterns of a particular plant. Nowadays crops face many traits/diseases. Damage of the insect is one of the major trait/disease. Insecticides are not always proved efficient because insecticides may be toxic to some kind of birds. It also damages natural animal food chains. A common practice for plant scientists is to estimate the damage of plant (leaf, stem) because of disease by an eye on a scale based on percentage of affected area. It results in subjectivity and low throughput. This paper provides a advances in various methods used to study plant diseases/traits using image processing. The methods studied are for increasing throughput & reducing subjectiveness arising from human experts in detecting the plant diseases.

### III. METHODOLOGY

Agriculture is a periodic process rather than a systemic process. The synergy of agriculture has impacted civilizations over time and has been a focal point for stabilized development. The digital age is a Pandora 's Box of technological advancement, integration of an archaic yet an essential sector like agriculture defines the stability of the bureaucracy. The tillable field is then surveyed. Surveying is a preliminary process that entails details regarding the composition and structure of the land to be cultivated. The essential regions or the tillable regions are cordoned off and its soil composition is studied. The texture of the soil is further tested and a suitable seed is selected for cultivation. The aforementioned process is easily integrated in Ceres. After a formal survey is carried out, the schematics are converted into a machine readable format. In the older method the seed dispersal was left at the discretion of the farmer, there wasn't any verifiable means to check the accuracy of the seed dispersal, but it's not the same in case of Ceres. Seed dispersal is one of the real time applications of Ceres. The algorithm provides a systematic dispersion of the seeds. Certain practices like sowing, ploughing are easily integrated with Ceres. The core functionality of Ceres is displaying the algorithm through system driven agro tools. The process of ploughing is laborintensive and demands hours of manual work. Ceres performs the actions of an ordinary farmer and also provides a higher throughput. The moisture content of the soil is checked for optimum level. Irrespective of the order of the process, the device readjusts it's working based on the completion of the previous process. The sown seeds are watered in adequate quantities. Often a seed fails to flower due to excessive discharge of water. The moisture across the field isn't always uniform, in cases as such Ceres records the moisture content of the soil at every equal distance. If the moisture is within the threshold value then the seed is planted and no water is fed else the converse takes place.

Diseases have always been a chronic factor irrespective of the plant cultivated. Ceres has been equipped with a unique and robust disease detection mechanism. After months into cultivation the plants are checked for signs of recorded diseases. Once identified by cross checking with a nationwide disease database Ceres then treats the plant detected with the required pesticides. Accessibility of any asset is a prerequisite for any consumer. The goal of autonomy is realized in Ceres with the help of a ZigBee module. With this module the client can access the device and obtain an on ground analysis of the progress made.

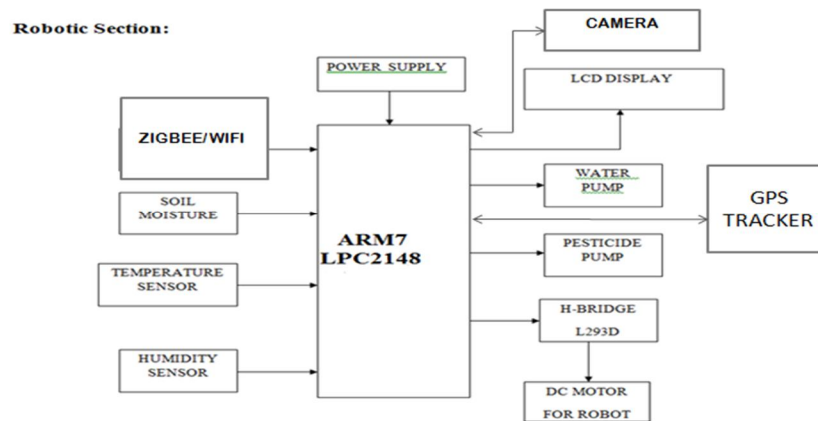

**A. Flowchart**

The survey map of the field is first fed to the robot. The robot then senses the temperature, humidity and soil moisture content. In case the temperature and humidity is more, and soil moisture content is less, then the plants must be irrigated more. The field is then ploughed at regular distance between the seeds, which is already calculated, depending upon the types of seeds. Once the seeds are sown, the field is leveled again by a leveler. The robot is connected to a chassi instead of a wheel so as to provide continuous motion and to avoid the obstacles. The caterpillar motion helps the robot to move even when there is an obstacle and it also helps the robot to accurately sow the seeds. Once the seeds are sown according to the field map, the plants are irrigated depending on the requirements of that particular type of plant. There are two modes of operation: manual and the automatic modes. In the manual mode of operation, the farmer operates the robot during its working. In the automatic mode of operation, the robot is operated automatically.

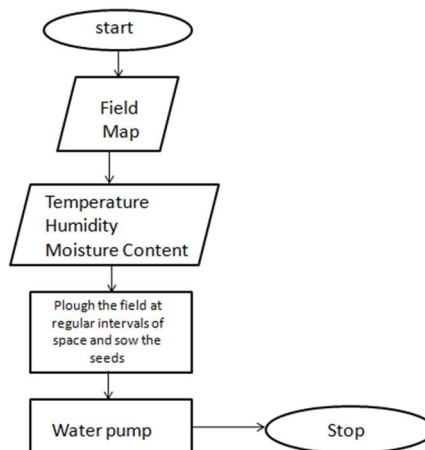

**B. Disease Detection**

Once the plant is grown up, the disease detection is performed. The images of the plant is first captured and the compared with the previously provided data base. If the disease detected is present in the data base provided, then the farmer is notified about the type of disease it is affected. The farmer will also be notified about which pesticide that has to be used in order to rectify the disease. Then the farmer has to feed the robot with the respective pesticide. The robot then sprinkles the fed pesticide to the disease detected plants.

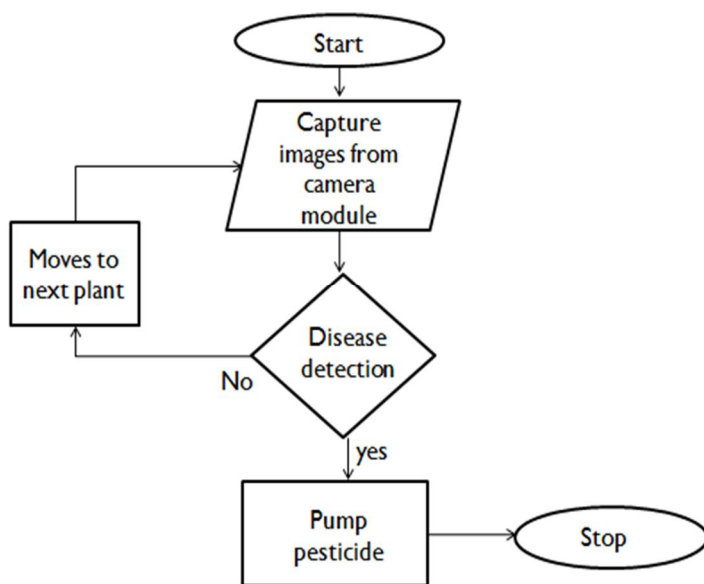

#### IV. APPLICATIONS

Agricultural robots automate slow, repetitive and dull tasks for farmers, allowing them to focus more on improving overall production yields. Some of the most common robots in agriculture are used for:

- A. Ploughing, sowing and leveling.
- B. Irrigation.
- C. Disease detection.
- D. Pesticide spraying.

Ploughing, sowing and leveling is one of the most popular robotic applications in agriculture due to the accuracy and speed that robots can achieve to improve the quality of yield.

Irrigating crops has traditionally used a lot of water is quite inefficient. Robot-Assisted Precision Irrigation can reduce wasted water by targeting specific plants. Ground robots autonomously navigate between rows of crop and pour water directly at the base of each plant.

Management of crops from early stage to mature harvest stage involves identification and monitoring of plant diseases. It provides a small, portable and reliable platform to automatically survey farmland, detect diseases as well as spray the pesticide.

Spraying pesticides by using robots is the innovative technique used in the field of agriculture. Robots are used to spray pesticides to prevent the spread of plant diseases. Farmers would know the exact location where the plants are affected and number of plants affected in the entire plot

#### V. CONCLUSION

An initial outcome of this study indicates that most of these systems that which work autonomously are more flexible than traditional systems. The benefits of reduction in labor costs and restrictions on the number of daily working hours significantly improved. Thus it has made possible to automate the most significant working routines. However some have failed due to the requirement of accuracy of specific tasks. In addition, at this stage of development, the initial investment are still relatively high but it seems possible to design economic viable robotic systems for grass cutting, crop scouting and autonomous weeding. Findings show that there is a significant potential for applying these systems if it's possible to impose adequate control and safety regulations systems at reasonable costs. Moreover, a comparison between different European countries indicates that labor costs, cost rotation and farm structure may have a tremendous impact on the potential use of these systems.

#### REFERENCES



- [1] Pota, H., Eaton, R., Katupitiya, J., & Pathirana, S. D. (2007, August). Agricultural robotics: A streamlined approach to realization of autonomous farming. In *Industrial and Information Systems, 2007. ICIIS 2007. International Conference on* (pp. 85-90). IEEE.
- [2] Amie, S. C. M., & Mohanraj, T. (2009). Automation and emerging technology development of 2d seed sowing Robo. *Journal of Agricultural Science (Toronto)*, 1(1), 33-52.
- [3] Zanwar, S. R., & Kokate, R. D. (2012). Advanced Agriculture System. *IAES International Journal of Robotics and Automation*, 1(2), 107.
- [4] Praveena, R., & Srimeena, R. (2015, July). Agricultural Robot for automatic ploughing and seeding. In *Technological Innovation in ICT for Agriculture and Rural Development (TIAR), 2015 IEEE* (pp. 17-23). IEEE.
- [5] Shivaprasad, B. S., Ravishankara, M. N., & Shoba, B. N. (2014). Design and implementation of seeding and fertilizing agriculture robot. *International Journal of Application or Innovation in Engineering & Management (IJAIEM)*, 3(6), 251-255.
- [6] Lei, F., & Yong, H. (2005). Study on dynamic model of tractor system for automated navigation applications. *Journal of Zhejiang University-SCIENCE A*, 6(4), 270-275.
- [7] Katupitiya, J., Eaton, R., Cole, A., Meyer, C., & Rodnay, G. (2005, April). Automation of an agricultural tractor for fruit picking. In *Proceedings of the 2005 IEEE International Conference on Robotics and Automation* (pp. 3201-3206). IEEE.
- [8] Khirade, S. D., & Patil, A. B. (2015, February). Plant disease detection using image processing. In *2015 International conference on computing communication control and automation* (pp. 768-771). IEEE.
- [9] Patil, J. K., & Kumar, R. (2011). Advances in image processing for detection of plant diseases. *Journal of Advanced Bioinformatics Applications and Research*, 2(2), 135-141.



10.22214/IJRASET



45.98



IMPACT FACTOR:  
7.129



IMPACT FACTOR:  
7.429



# INTERNATIONAL JOURNAL FOR RESEARCH

IN APPLIED SCIENCE & ENGINEERING TECHNOLOGY

Call : 08813907089  (24\*7 Support on Whatsapp)