



IJRASET

International Journal For Research in
Applied Science and Engineering Technology



INTERNATIONAL JOURNAL FOR RESEARCH

IN APPLIED SCIENCE & ENGINEERING TECHNOLOGY

Volume: 7 Issue: IV Month of publication: April 2019

DOI: <https://doi.org/10.22214/ijraset.2019.4256>

www.ijraset.com

Call:  08813907089

E-mail ID: ijraset@gmail.com

PLC Based CB Endurance Controller

Tukaram Pandhare¹, Sagar Mali², Ankit Patil³, Pranay Kudale⁴, Nitesh kumar Thakur⁵
^{1, 2, 3, 4, 5}MET, India

Abstract: We have presented the idea to control endurance test and no load test on any type of circuit breaker using PLC. Our aim is to minimize the problems and difficulties that physically challenged users while conducting the endurance test and no load test on switchgear. This design involves various stages consisting of the PLC, Variable Power supply, Relays and Switches. This controller performs endurance test and no load test on all type of high voltage circuit breaker. This test is necessary to stabilize the mechanism and to identify early infant mortality failures in the circuit breaker assembly.

I. CIRCUIT BREAKER DEFINITION

A mechanical device capable of making, carrying and breaking currents under normal circuit conditions and also making, carrying for a specific time and breaking currents under specified abnormal circuit conditions such as those of short circuit.

II. WORKING PRINCIPLE OF CIRCUIT BREAKER

The circuit breaker mainly consists of fixed contacts and moving contacts. In normal "on" condition of circuit breaker, these two contacts are physically connected to each other due to applied mechanical pressure on the moving contacts. There is an arrangement stored potential energy in the operating mechanism of circuit breaker which is realized if switching signal given to the breaker. The potential energy can be stored in the circuit breaker by different ways like by deforming metal spring, by compressed air, or by hydraulic pressure. But whatever the source of potential energy, it must be released during operation. Release of potential energy makes sliding of the moving contact at extremely fast manner. All circuit breaker have operating coils (tripping coils and close coil), whenever these coils are energized by switching pulse, and the plunger inside them displaced. This operating coil plunger is typically attached to the operating mechanism of circuit breaker, as a result the mechanically stored potential energy in the breaker mechanism is released in forms of kinetic energy, which makes the moving contact to move as these moving contacts mechanically attached through a gear lever arrangement with the operating mechanism. After a cycle of operation of circuit breaker the total stored energy is released and hence the potential energy again stored in the operating mechanism of circuit breaker by means of spring charging motor or air compressor or by any other means. Till now we have discussed about mechanical working principle of circuit breaker. But there are electrical characteristics of a circuit breaker which also should be considered in this discussion of operation of circuit breaker.

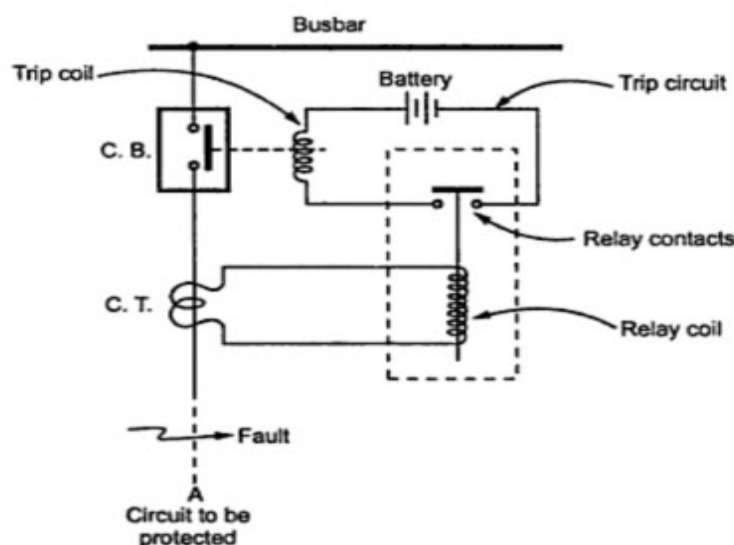

Fig1: Trip circuit of C.B.

III. TYPES OF CIRCUIT BREAKER

A. According Different Criteria There Are Different Types Of Circuit Breaker

- 1) According to their arc quenching media the circuit breaker can be divided as-
 - a) Oil circuit breaker.
 - b) Air circuit breaker.
 - c) SF₆ circuit breaker.
 - d) Vacuum circuit breaker.
- 2) According to their services the circuit breaker can be divided as-
 - a) Outdoor circuit breaker
 - b) Indoor breaker.
- 3) According to the operating mechanism of circuit breaker they can be divided as-
 - a) Spring operated circuit breaker.
 - b) Pneumatic circuit breaker.
 - c) Hydraulic circuit breaker.
- 4) According to the voltage level of installation **types of circuit breaker** are referred as-
 - a) High voltage circuit breaker.
 - b) Medium voltage circuit breaker.
 - c) Low voltage circuit breaker.

IV. TESTING OF CIRCUIT BREAKER

Testing of circuit breakers is more difficult as compared to other electrical equipment like transformer or machine because the short circuit current is very large.

Testing of the circuit breaker is mainly divided into two groups,

- 1) Type tests, and
- 2) Routine tests.

A. Type Tests of Circuit Breaker

Type tests are conducted for the purpose of proving the capabilities and confirming the rated characteristic of the circuit breaker. Such tests are conducted in the specially built testing laboratory, Type tests can be broadly classified as the mechanical performance test, thermal test, dielectric or insulating test, short circuit test for checking the making capacity, breaking capacity, short time rating current and operating duty.

- 1) *Thermal Test:* Thermal tests are carried out to check the thermal behavior of the circuit breakers. The breaker under test deal with the steady-state temperature rises due to the flow of its rated current through its pole in a rated condition. The temperature rise for rated current should not exceed 40° for current less than 800A normal current and 50° for normal value of current 800A and above.
- 2) *Dielectric Test:* These tests are performed to check power frequency and impulse voltage withstand capacity. Power frequency tests are kept on a new circuit breaker; the test voltage changes with a circuit breaker rated voltage. The test voltage with a frequency between 15-100Hz is applied as follows. (1) between poles with circuit breaker closed (2) between pole and earth with circuit breaker open, and (3) across terminals with circuit breaker open. In impulse tests impulse voltage of specified magnitude is applied to the breaker. For outdoor circuit dry and wet tests are conducted.
- 3) *Short -Circuit Test:* Circuit breakers are subjected to sudden short-circuits in short-circuit test laboratories, and oscillograms are taken to know the behavior of the circuit breakers at the time of switching in, during contact breaking and after the arc extinction. The oscillograms are studied with particular reference to the making and breaking currents, both symmetrical and asymmetrical restriking voltages, and switchgear is sometimes tested at rated conditions.

B. Endurance Test / Mechanical Performance Test

Endurance Test of Circuit Breaker is conducted to check the healthiness of its mechanical parts i.e. operating mechanism. In this test, Circuit Breaker is operated several times and checked for any damage of its mechanical parts / contacts. The breaker should be in a position to open and close satisfactorily. This test is also called Mechanical Test.

In mechanical tests, the circuit breaker is opened and closed several times (1000). Some operations (about 50) are conducted by energizing the relays, remaining are by closing the trip circuit by other means. Mechanical tests on high voltage AC circuit breakers

are conducted without current and voltage in the main circuit. Out of the 1000 operations, about 100 operations are made by connecting the main circuit (contacts) in series with trip circuit.

No adjustment or replacement of parts is permitted during the mechanical tests. However, lubrication is After the tests, the contacts, linkages and all the other parts should be in good condition and should not show any permanent deformation or distortion. The dimensions should be within original limits. During repeated operations of the circuit-breaker, the weaker parts in the assembly may fail. The circuit-breaker is then considered to have failed in the mechanical test. The tests are then to be repeated after improvement in the design and manufacture. Successful performance in Mechanical Endurance Tests proves the adequacy of design and also good quality of materials and manufacture.

Though 1000 close-open cycles are specified in the standards, the manufacturer may conduct 10,000 or more operations to ascertain the reliability and for getting design data.

C. No Load Operation Test

The no load operation tests include the following operations:

- 1) Closing(C)
- 2) Opening (O)
- 3) Operating sequence

O-0.3sec-CO-3min-CO (for rapid auto reclosure)

O-3min-CO-3min-CO or

CO-30sec-CO (for non-rapid auto reclosure)

No load tests are conducted prior of short circuit tests.

No load tests are carried out with following conditions:

In spring mechanism the trip coil should operate at 85% and 110% of rated supply voltage.

With solenoid operated mechanisms tests are made with closing solenoid energized at both 105% and 85% of rated supply voltage of closing coil.

V. SYSTEM DESCRIPTION

Fig.:2 shows the block diagram of the given system.

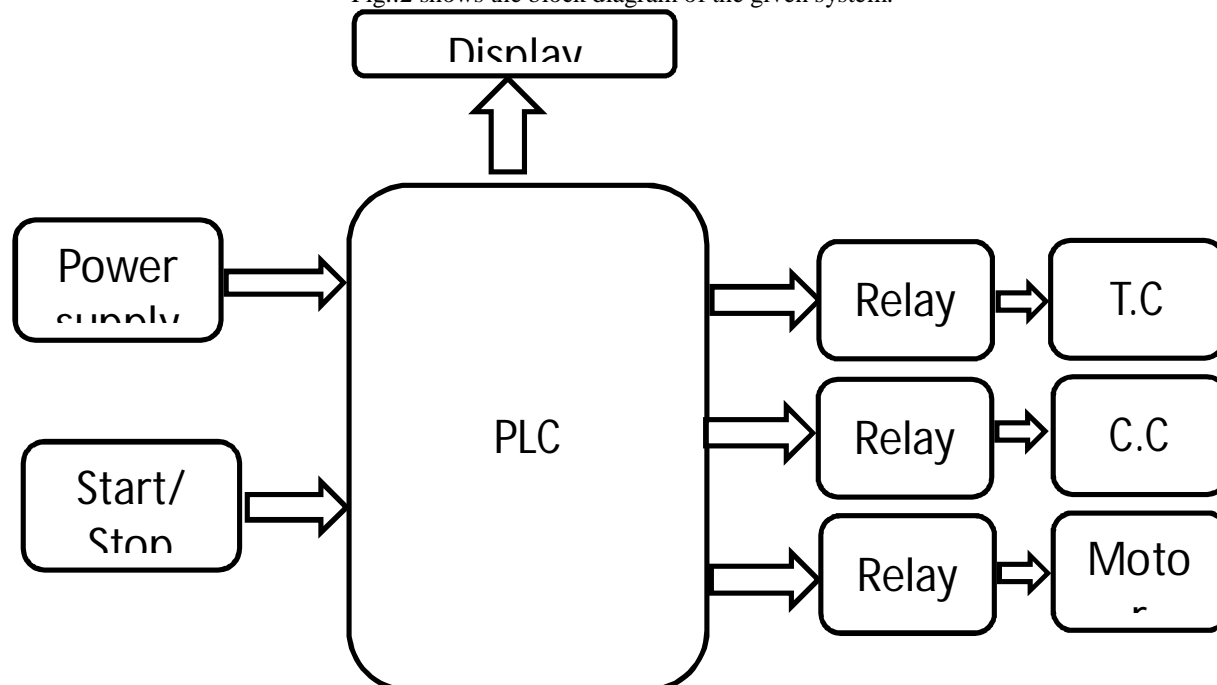

Fig.:2 Block diagram

In this controller input I1,I2,I3,I4,I5,I6 and output Q1,Q2,Q3,Q4. In input section we have connected push button for start or stop of the operation. In output section output (Q1) connected to the auxiliary coil of relay1 and another contact of relay 1 connected to trip

circuit, output (Q2) is connected to the auxiliary coil relay 2 and another contact of relay 2 connected to close circuit, output (Q3) connected to the auxiliary coil relay 3 and another contact of relay 3 connected to motor output (Q4) connected to the buzzer. In this system buzzer is used for the indication and alarm purpose.

Fig.:3 shows the schematic wiring diagram of the system.

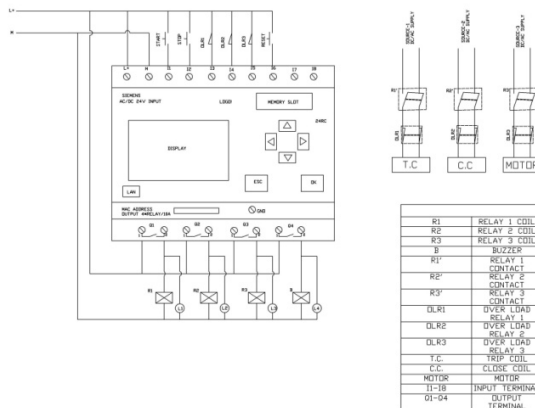

Fig.:3 Circuit diagram

A. Operation of Given System

The start push button is given as an input to the PLC.

Further, PLC scans the input. The output-1 of the plc is given to the relay-1 and then the relay-1 is energized and supply goes to the trip coil and trips the circuit breaker. During this action, the trip spring gets depressed and breaks the circuit.

After the fault is cleared, the command goes to close coil and close the circuit as well as close spring gets depressed. At this instance, trip spring gets charged (Compressed). This happens as there exist an interlock between the two springs. At this time, the circuit is closed and immediately supply goes to motor for charging of close spring.

When the fault reoccurs, the trip coil breaks the circuit as it is charged previously. But when the fault is cleared the close coil is unable to make the circuit since the close spring is de-energized. In order to re-energize the spring a motor is used. The motor then charges the close spring.

Fig.:4 shows the flowchart of the given system. Fig.:5 shows the program of the system.

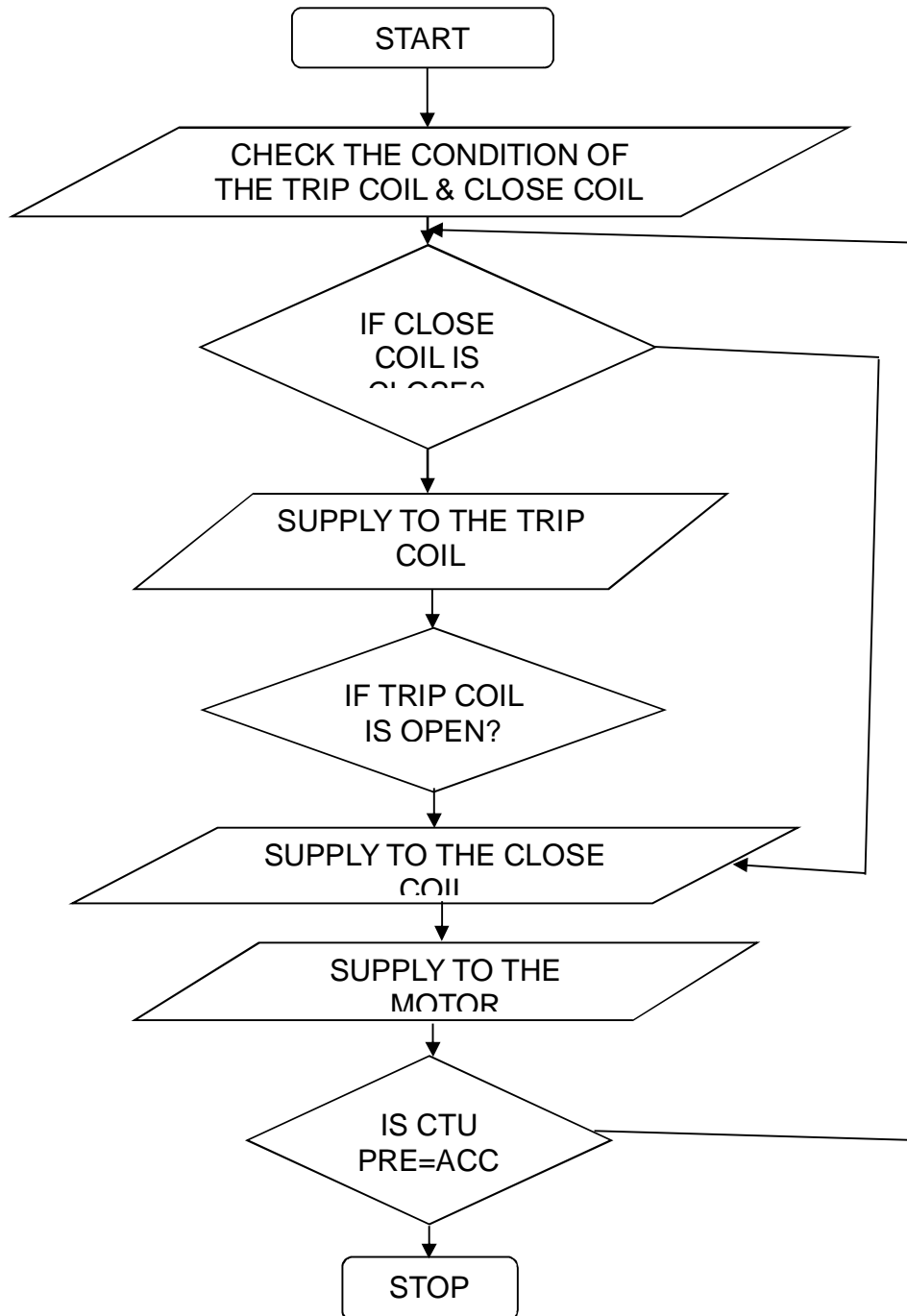

Fig.:4 Flow chart

- 1) Step 1): After pressing the START button coil L will be activated.
- 2) Step 2): Timer T1 will be activated due to coil L.
- 3) Step 3): Timer 2 enable bit would be energized after Timer 1 is activated and a supply is provided to trip Coil. After some time, the value of timer 1 would be equals to the accumulator value which would be equals to preset value, i.e. preset value = accumulator value. Because of that Done Bit would be energized and the supply to the trip coil would be Stopped

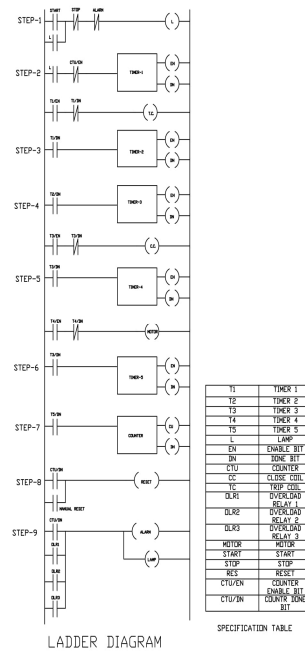

Fig.: 5 Ladder logic

- 4) Step 4): After the supply to the trip coil is stopped Timer 2 is activated and when the preset value = accumulator value then the Done Bit of Timer 2 would be energized and next Timer would be activated.
 - 5) Step 5): Timer 3 is activated when supply is given to close coil and Enable bit is energized. After some time, accumulator value = preset value then Done Bit of T3 would be activated and supply of the close coil is Stopped.
- Timer 4 and Timer 5 would be activated after the supply to close coil is cut and motor is started immediately then after. When the accumulator value = Preset value then Timer 4 Done bit would be activated and supply to the motor would be cut. When Timer 5 accumulator value = preset value a pulse would be send to the counter and one cycle is completed. Then Enable Bit of the counter is energized and the cycle restarts.

B. Advantage

- 1) The Primary application involved solution to reduce the no load testing time of circuit breaker.
- 2) Complete elimination of man power
- 3) Easy to setup and use
- 4) Automatic control and display of balance operations.

VI. CONCLUSION

Performs no load mechanical test and endurance test on circuit breaker by using only one controller and one or more than one circuit breaker tested at a time.

REFERENCE

[1] S.S. Rao, "Switchgear protection and power systems"
 [2] J.B. Gupta "switchgear and protection"



10.22214/IJRASET



45.98



IMPACT FACTOR:
7.129



IMPACT FACTOR:
7.429



INTERNATIONAL JOURNAL FOR RESEARCH

IN APPLIED SCIENCE & ENGINEERING TECHNOLOGY

Call : 08813907089  (24*7 Support on Whatsapp)